



ProJet™ 1200

Professional 3D Printer



User Guide

Original Instructions

CONTENTS

1	INTRODUCTION	1
	Copyright	1
	FCC Notice	1
	Compliance	1
	Warranty	2
	Limitation of Liability	2
2	IMPORTANT SAFETY INFORMATION	3
	Safety Symbols and Definitions	3
	Safety Guidelines	4
	General Safety Guidelines	4
	High Voltage Potential and Electrical Safety	4
	Ultraviolet (UV) Safety	4
	Ultraviolet (UV) Safety	4
	Consumable Safety Guidelines	5
	VisiJet® FTX Material	5
	FTX Material Cartridge	5
	VisiJet FTX Cartridge Removal	5
	VisiJet FTX Material Disposal	5
	VisiJet FTX Material Handling	5
	VisiJet FTX Material Safety	6
	VisiJet® FTX Material Usage	6
	Ultraviolet (UV) Safety	6
3	AT-A-GLANCE	7
	About the Printer	7
	Connections	8
4	SPECIFICATIONS AND REQUIREMENTS	9
	Specifications	9
	Printer	9
	Material Cartridge	9
5	UNPACKING AND SETTING UP YOUR PROJET 1200	10
	Contents	10
	Unpacking the ProJet 1200	11
	Printer Setup	14
	Installing the Curing Bulb	14
	Installing the Material Cartridge	15
	Installing the Print Platform	16
6	SYSTEM REQUIREMENTS	17
	Polygon Mesh	17
	Create Account	18
	Installing the 3DSPRINT™ Software	18
	Install Application	20
	Checking for Updates	23

How to Use	23
Connecting The Printer	24
Connecting Printer Using a USB Connection	24
Selecting Printer for Project	25
Activating Printer	25
How to Activate Printer	25
Set Current Printer	25
Add a Printer	26
Add a Virtual Printer	26
Remove a Printer	26
Test Post Cure	27
How to use:	27
Check Material Cartridge	27
Platform Up	28
Platform Down	28
Post Cure	28
How to Use:	28
Test Projector	28
How to use:	28
Update Firmware	29
Updating Firmware Through the 3DSPRINT	29

7 OPERATING THE PRINTER	30
Software Overview	30
Printing a Part	31
Launch 3DSPRINT	31
Selecting Printer, Material, and Print Mode	31
Printing a Print	32
Z Compensation	34
Print Queue	36
How to Use:	36
Print Queue Navigation	36
Printer List	37
Print Properties	37
Adding a File to the Queue	37
Remove the Part from the Printer	38
Cleaning Parts	39
Cleaning Parts by Manually Dipping	39
Cleaning Parts Using an Ultrasonic Cleaner	40
Special Consideration when Cleaning Parts	41
Changing the Isopropyl Alcohol in Containers 1 and 2	41
Cleaning Parts with 70% Isopropyl Alcohol	41
Cure and Post Process the Part	42

8 USER MAINTENANCE	43
Replacing the Curing Bulb	43
Cleaning the Unit	44

9 SERVICE AND SUPPORT	45
Service Contact	45
Repacking the ProJet 1200	46

1 INTRODUCTION

Thank you for purchasing the ProJet® 1200 3D printer.

The ProJet 1200 professional 3D Printer produces small, detailed parts for casting, prototyping and end-use parts from 3-D solid Computer-Aided Design (CAD) models. It is intended to be used as a 3-dimensional output device to communicate design intent with durable, physical parts. Parts produced can be used in all phases of design, from a concept build to functional testing and assembly verification. For example, a part can be used as a tool to communicate design intent, to verify the fit of a new or existing component part or to create a rugged, plastic prototype of a new invention. Parts made on the ProJet 1200 are ideal for dental wax-ups, jewelry and other castings, and durable, stiff parts are also great for plastic prototypes.

These parts are generated in the rapid prototyping (RP) environment under the control of the printer operators. It does not require a special technical staff to supervise the system. All design and process considerations are compatible with an RP environment. The three-dimensional solid parts that are printed consist of an ultraviolet (UV) curable material. The resin transfer mechanism provides a controlled layer thickness of VisiJet® part material which is deposited and patterned using a proprietary image technology which 3D Systems® has developed. When creating the pattern, the VisiJet® material undergoes a phase change. This phase change converts the liquid material into a solid polymer. When the print is complete, the part adheres to the print pad. This pad along with the part is removed from the print platform and the part is cleaned and cured to provide a finished part.

COPYRIGHT

©2014 by 3D Systems®. All rights reserved.

Under the copyright laws, this user guide may not be copied, in whole or in part, without the written consent of 3D Systems. The ProJet logo is a trademark of 3D Systems and is registered in the U.S. Use of this logo without the prior written consent of 3D Systems may constitute trademark infringement and unfair competition in violation of federal and state laws.

Every effort has been made to ensure that the information in this manual is accurate. Other company and product names mentioned herein are trademarks of their respective companies. Mention of third-party products is for informational purposes only and constitutes neither an endorsement nor a recommendation.

The product described in this user guide incorporates copyright protection technology that is protected by method claims of certain U.S. and foreign patents and other intellectual property rights that are owned by 3D Systems®. Reverse engineering is prohibited.

VisiJet® is a registered trademark of 3D Systems.

FCC NOTICE

This equipment has been tested and found to comply with the limits for a class “A” digital device, pursuant to Part 15 of the FCC Rules. These limits are designed to provide reasonable protection against harmful interference. This equipment generates, uses, and can radiate radio frequency energy and, if not installed and used in accordance with the instruction manual, may cause harmful interference to radio communications. Operation of this equipment in a residential area is likely to cause harmful interference in which case the user will be required to correct the interference at their expense.

COMPLIANCE

This equipment conforms with International Electric Committee (IEC) 60950-1 and meets the requirements of the applicable EC directives.



WARRANTY

3D Systems warrants that the ProJet 1200 3D Printer will be free from defects in materials and workmanship, during the applicable warranty period, when used under the normal conditions described in the documentation provided to you, including this User Guide. 3D Systems or its authorized service provider will promptly repair or replace the ProJet 1200 3D Printer, if required, to make it free of defects during the warranty period. This warranty excludes (i) normal consumable or expendable parts (such as Material Cartridges), (ii) repairs required during the warranty period because of abnormal use or conditions (such as riots, floods, misuse, neglect or improper service by anyone except 3D Systems or its authorized service provider), and (iii) repairs required during the warranty period because of the use of non-integrated, non-approved or non-licensed materials with the ProJet 1200 3D Printer. The warranty period for the ProJet 1200 3D printer is for one (1) year and starts at the earliest of (i) the date your ProJet 1200 3D printer is activated or (ii) "ninety (90) days after the ProJet 1200 3D Printer is shipped from 3D Systems to the end customer or to the reseller or retailer that sold the ProJet 1200 3D Printer to the end customer."

THIS WARRANTY IS THE ONLY WARRANTY PROVIDED FOR THE PROJET 1200 3D PRINTER. TO THE MAXIMUM EXTENT PERMITTED BY LAW, 3D SYSTEMS EXPRESSLY DISCLAIMS ALL OTHER WARRANTIES FOR THE PROJET 1200 PRINTER AND EACH OF ITS COMPONENTS, WHETHER THOSE WARRANTIES ARE EXPRESS, IMPLIED OR STATUTORY, INCLUDING WARRANTIES OF MERCHANTABILITY AND FITNESS FOR INTENDED OR PARTICULAR PURPOSES.

LIMITATION OF LIABILITY

3D SYSTEMS WILL NOT BE RESPONSIBLE FOR INDIRECT, SPECIAL, CONSEQUENTIAL, EXEMPLARY OR INCIDENTAL DAMAGES (SUCH AS LOSS OF PROFIT OR EMPLOYEE'S TIME) REGARDLESS OF THE REASON. IN NO EVENT SHALL THE LIABILITY AND/OR OBLIGATIONS OF 3D SYSTEMS ARISING OUT OF THE PURCHASE, LEASE, LICENSE AND/OR USE OF THE EQUIPMENT BY YOU OR OTHERS EXCEED THE PURCHASE PRICE OF THE PROJET 1200 3D PRINTER.

2 IMPORTANT SAFETY INFORMATION

SAFETY SYMBOLS AND DEFINITIONS

Symbols used in this guide and on the product itself are identified to ensure correct usage, to prevent danger to the user and others and also to prevent property damage. The meanings of these symbols are described below.



NOTE: It is important that you read these descriptions thoroughly and fully understand the contents.



UV Radiation Hazard: Invisible UV radiation is accessible in the vicinity of this sign or behind the panel. Radiation can cause eye injury. Access panels are for service only and should be opened only by certified service personnel.



Electrical Shock Hazard: High voltage electricity is accessible in the vicinity of this sign or behind the access panel. High voltage can cause severe burns or death. Access panels are for service only and should be opened only by certified service personnel or trained maintenance personnel.



Hot Surface Hazard: A hot surface is accessible in the vicinity of this sign or behind the access panel. Avoid contact. Hot surfaces can cause severe burns. Access panels are for service only and should be opened only by certified service personnel or trained maintenance personnel.



Harmful Irritant Warning: Indicates that skin or eye irritation could result while exposed to a chemical composition.



Caution: Indicates something may happen that could cause loss of data, damage to equipment, or personal injury.



Pinch Point: Indicates hands and/or fingers potentially could be pinched when interacting with the equipment.



Wear Gloves: Wear gloves when handling uncured VisiJet® build material.



Ultraviolet Radiation Inside: Exposure may cause eye damage. Do not operate without covers. Wear UV eye protection.

SAFETY GUIDELINES



General Safety Guidelines

To ensure personal safety, follow these general safety guidelines when operating the printing system.

- Follow all safety rules in this section and observe all cautions and warnings in this guide.
- Do not use print materials without first reviewing its Material Safety Data Sheet (MSDS & SDS) which can be found at <http://www.3dsystems.com/support/materials/msds>.
- To prevent tripping, ensure power and communication cables are located away from the walking path to the printing system.
- If performing maintenance to this system, ensure step by step instructions and safety precautions are followed during the procedure.
- Operators of the printer should be trained to perform necessary tasks when printing a part according to the guidelines that are set forth in this manual. This includes understanding and following the safety and regulatory guidelines.
- Do not modify any safety features or make modifications to the printing system. Doing so is prohibited and voids warranty and contractual agreements.
- Use of part materials, print pads or parts other than genuine 3D Systems® ProJet® 1200 components may void warranty and other contractual agreements.
- To prevent potential skin-irritation and sensitization due to contact with the print material, follow all guidelines in Material Safety Data Sheet (MSDS).
- In the unlikely event that you are exposed to ultraviolet rays from the unit, proper precautions must be taken. To ensure your safety, UV protective eye wear and nitrile gloves should be worn when operating this equipment.
- Hazardous voltage exists inside the electrical module. Injury or death from electrical shock can result if the system's electrical box covers are removed. When installing replacement modules, ensure the power is off before removing panels.

HIGH VOLTAGE POTENTIAL AND ELECTRICAL SAFETY



High Voltage Potential

If the electrical module is in need of repair, power down the printer and unplug the power supply. Do not remove covers, doing so will void warranty and contractual agreements.



Electrical Safety

To operate the printer, the door must be closed.

This printer requires a grounded, 1-phase electrical power source with a service rating of 100 to 240 VAC~, 50/60 Hz, 5 A (max.).

ULTRAVIOLET (UV) SAFETY



Ultraviolet (UV) Safety

- In normal operation, the ultraviolet (UV) light is completely confined, so users are not exposed to potentially harmful emitted radiation.
- UV light from the printer could cause personal injury. Use recommended protective eye wear which blocks the UV light. It is recommended to never purposely stare directly into the printer during operation.
- To prevent eye injury, do not open the door when the ultraviolet (UV) light is activated. When the door are closed, it keeps UV radiation from escaping.
- Pay attention and follow the warnings contained in this guide concerning operation and printer's maintenance procedures.
- If the door is opened during operation, use the recommended protective eye wear which blocks the UV light.
- Hazardous voltage exists inside the electrical module. Injury or death from electrical shock can result if the system's electrical box covers are removed. When installing replacement modules, ensure the power is off before removing panels.

CONSUMABLE SAFETY GUIDELINES



NOTE: Follow all safety rules in this section and observe all cautions and warnings in this guide.

VisiJet® FTX Material

There are 6 available VisiJet FTX Materials, FTX Green, FTX Gold, FTX Silver, FTX Cast, FTX Clear, FTX Gray. Pay close attention to the follow handling and disposal requirements.

FTX Material Cartridge

Uncured material waste is classified as regulated, and in some areas hazardous, thereby requiring special packaging, transportation and disposal. Refer to your local environmental regulatory agency.

Applicable material “waste” includes cartridges (empty or full). Any cleaning supplies used to clean up uncured material should be disposed of in the same manner as the uncured material. To identify which disposal requirement applies, contact the local waste disposal service provider. (The local environmental regulatory agency should have a list of qualified providers in your area.) Give the disposal service provider a copy of the material’s MSDS and the SNUR (Significant New Use Regulation - U.S. only). The service will provide a report, indicating the disposal requirements that apply, as well as a quotation for regularly scheduled pickups.

3D Systems assumes no liability or responsibility for proper disposal of the uncured material. Proper disposal of the uncured material is the sole responsibility of the user.

VisiJet FTX Cartridge Removal



Wear protective gloves when removing the material tray from the printer. Remove the tray and place it in a disposable bag. Be careful not to spill, drop or expose other materials to the waste.



NOTE: Partially used cartridges should be returned to their original packaging to store for later use.

VisiJet FTX Material Disposal

ProJet 1200 3-D printer operators should be informed about the potential hazards of part material prior to performing operations which may result in exposure to uncured material. This includes the removal and disposal of empty cartridges or unlikely spills that may occur during operation.

Leaks indicate a serious malfunction. The first priority is to protect users from inadvertently touching the material. Handling uncured material requires the use of gloves and other protective equipment to ensure there is no direct skin contact. If uncured spills occur, promptly remove the spilled material, and dispose of the waste material according to local environmental regulations.

If a problem with the printer occurs, discontinue use until the problem is diagnosed. Resolve the problem before continuing to operate the printer.

Small spills of uncured liquid can be cleaned up using disposable towels. After wiping the spill, wipe printer surfaces using a lint free cloth and clean with Isopropyl alcohol or window cleaner.

Cleaning spills on carpeting can be difficult. Avoid placing printer over carpeted areas or use a barrier to avoid the possibility of carpet damage. Advise any service provider involved (e.g. carpet cleaning service or disposal service) of the nature of the spilled material. Provide the MSDS and other material information prior to their contact to the material. Provide material disposal requirements and cleaning solutions if the material is uncured.

Tools that may be contaminated with the material should be cleaned prior to reuse. Recommended solvents such as IPA are normally required to clean tools. A final wash with soap and water will remove any excess of print material.

VisiJet FTX Material Handling

Upon receipt of the part material shipment, inspect the carton for signs of physical damage and evidence of leakage on the exterior. If leakage is observed, do not open carton; immediately contact 3D Systems’ Customer Support Hotline. If leakage is not present, store materials in their material kits until they are ready to use. Materials should be kept indoors in a cool, dry area with adequate ventilation with temperatures between 16°C (60°F) and 27 °C (80°F). **DO NOT EXCEED A MAXIMUM STORAGE TEMPERATURE OF 35°C (95°F).**

Keep materials away from direct sunlight, heat, flames and other direct light or UV energy sources. For optimal results, keep stored cartons closed and sealed until the cartridge is ready for use. Authorized 3D Systems VisiJet FTX Material should only be used in the printer.

VisiJet FTX Material Safety

Training: New users should be trained in the hazards and management of materials. Such training should be provided before they begin working with the printer or disposal of material waste.

Once the print material has completed its printing cycle, the print needs to be removed, cleaned and cured, rendering it safe to handle. When print material is uncured- meaning in a paste or wet form, do not touch uncured print material directly without protective gloves. If uncured material is observed, ensure the safe handling of uncured print material.

Flammability and Combustibility: Do not expose print material to heat (at or above 110°C/ 230°F), flames, sparks, or any source of ignition. (Though the U.S. Department of Transportation does not consider this material a “flammability hazard,” they do classify it as combustible based on their flash points.) For more information on VisiJet® Material flash points and combustibility, see the VisiJet® Material MSDS/SDS packaged with the material cartridge.

Health Hazards: Any chemical may exert harmful effects if it enters or contacts the body in sufficient quantities. Uncured material is a sensitizer, and can cause allergic reactions if it comes in contact with the skin. Always wear chemically resistant protective gloves, nitrile or neoprene gloves are recommended. DO NOT use latex gloves. Consult the MSDS for specific information about the sensitization potential.

Sensitization dermatitis is the result of an allergic reaction to a given substance. In some cases, direct skin contact is necessary to cause sensitization. It is possible for individuals to become sensitized to a substance even after a trouble-free period of exposure. Many factors affect a person’s susceptibility including: existing skin conditions, personal habits, and individual sensitivity. Even slight exposure can sometimes trigger a severe outbreak of dermatitis. Since sensitization is permanent, a sensitized individual should avoid further contact with the sensitizing agent.

To ensure personal safety, uncured print material should not be present where food and drink are stored, prepared or consumed. As a precaution, after handling material, wash hands with soap and water before handling food. Finished parts (cured) can be handled or disposed of in the same manner as standard household plastic products. These parts are not recyclable.

Inhalation: Under normal operation, inhalation is not an expected exposure method.

Exposure Control: The printer has a variety of built-in safety features that are designed to prevent operator exposure. Do not try to change or disable these features.

Personal Protective Equipment and Skin Protection: Exposure to uncured material may occur when removing and disposing spent print cartridges. To prevent contact, wear chemically resistant protective gloves - nitrile or neoprene gloves are recommended. Wear safety glasses with side shields to provide eye protection in the event of a leak or spill of uncured print material.

Respiratory Protection: Because of the printer’s built in controls, respiratory protection is not necessary during normal operation. The status screen in the client software will prompt the user to change the printer’s air filters at prescribed times. Individual use may vary depending on the run time of the modeler. A NIOSH-approved (or equivalent) dust mask is recommended when dry sanding cured parts.

Cured Material: The FTX Materials have not been through an Acute Systemic Toxicity Test or a Intracutaneous Test . The Acute Systemic Toxicity Test measures the irritant effect of the test material and governs its human hazard potential. Toxicity is determined by oral, dermal and inhalation. The Intracutaneous Test is a specific test administers the material straight to the tissues it will be in contact during normal use without protection of the skin or any other body system. This will allow the testing team to assess the response of particular tissues to the material. For this reason we do not recommend prolonged exposure with cured material, letting material coming in contact with the mouth or tongue.

VisiJet® FTX Material Usage

The VisiJet FTX Material batch number and date code is indicated on the material kit label. For best results, please use materials by the date indicated. Before removing cartridge from its protective poly bag, and before loading it in to the printer, inspect the cartridge for signs of leakage or physical damage. Do not load cartridge that is leaking or is damaged. Dispose of it according to your local regulations.

ULTRAVIOLET (UV) SAFETY



CAUTION: Ultraviolet (UV) Safety

- In normal operation, the ultraviolet (UV) light is completely confined, so users are not exposed to potentially harmful emitted radiation.
- UV light from the printer could cause personal injury. Use recommended protective eye wear which blocks the UV light. It is recommended to never purposely stare directly into the printer during operation.
- To prevent eye injury, do not open the door when the ultraviolet (UV) light is activated. When the door are closed, it keeps UV radiation from escaping.
- Pay attention and follow the warnings contained in this guide concerning operation and printer’s maintenance procedures.
- If the door is opened during operation, use the recommended protective eye wear which blocks the UV light.
- Hazardous voltage exists inside the electrical module. Injury or death from electrical shock can result if system’s electrical box covers are removed. When installing replacement modules, ensure power is off before removing panels.

3 AT-A-GLANCE

ABOUT THE PRINTER

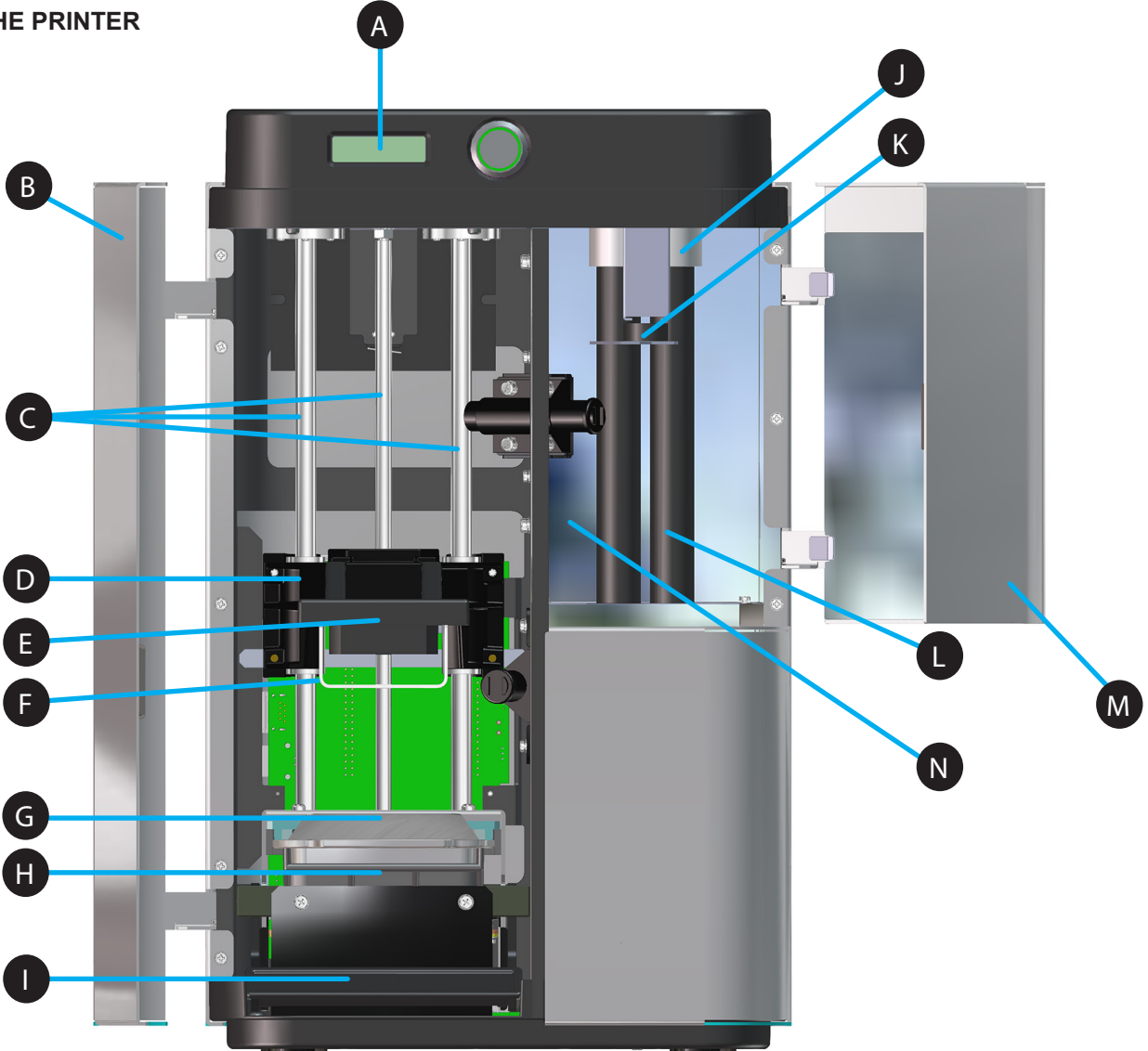

- A LCD Display
- B Print Door
- C Elevator Guide Rods
- D Elevator
- E Print Platform Clamp Lever
- F Print Platform
- G Material Cartridge Clamp
- H Print Cartridge Support
- I Material Cartridge Clamp Lever
- J UV Curing Bulb Socket
- K Curing Chamber Carousel
- L UV Curing Bulb
- M Curing Chamber Door
- N Curing Chamber

CONNECTIONS

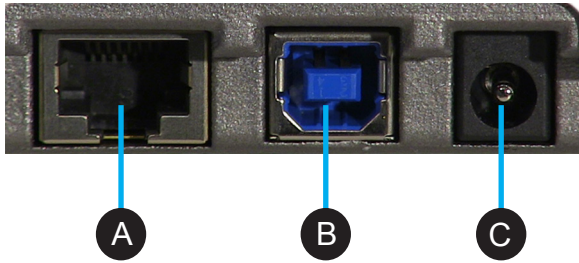

- A Ethernet
- B USB
- C Power Input

4 SPECIFICATIONS AND REQUIREMENTS

SPECIFICATIONS

Printer

ProJet® 1200

Net Build Volume (xyz)	43 x 27 x 150 mm (1.69 x 1.06 x 5.90 in)
Native Resolution (xy)	56 micron (effective 585 dpi*)
Layer Thickness	0.03 mm (0.0012 in)
Vertical Build Speed	14 mm/hour (0.55 in/hour)
Material	VisiJet® FTX Green, Gray, Cast, Silver, Gold, Clear
Material Packaging	All-in-one cartridge with built-in print window
Post-processing	Built-in UV Curing Station
Software	-Easy Installer
	-Network Connection
	-Windows®-based OS
	--Automatic and optimized supports
File Input	STL
Electrical Requirements	100-220V 50/60 Hz
Network Ready	

* Enhanced LED DLP technology provides an effective resolution of 585 DPI.

Material Cartridge

VisiJet FTX® Material

Properties	Condition	Values	Values	Values	Values	Values	Values
Name		VisiJet FTX® Green UV Curable Plastic	VisiJet FTX® Cast UV Curable Plastic w/Wax	VisiJet FTX® Gray UV Curable Plastic	VisiJet FTX® Clear UV Curable Plastic	VisiJet FTX® Silver UV Curable Plastic	VisiJet FTX® Gold UV Curable Plastic
Description		Tough castable plastic	Wax and plastic hybrid for delicate castings	Primer gray general purpose	Transparent tough	Metallic silver appearance	Metallic gold appearance
Composition		UV Curable Plastic	UV Curable Plastic with Wax	UV Curable Plastic	UV Curable Plastic	UV Curable Plastic with Metallic Flakes	UV Curable Plastic with Metallic Flakes
Color		Dark Green	Light Green	Gray	Clear	Silver	Gold
Cartridge Qty.		30g	30g	30g	30g	30g	30g
Density @ 25° (liquid)		1.04 g/cm ³	1.01 g/cm ³	1.12 g/cm ³	1.1 g/cm ³	1.16 g/cm ³	1.16 g/cm ³
Tensile Strength, MPa	ASTM D638	22	2.2	28	24	16	16
Tensile Modulus, MPa	ASTM D638	1700	154	1288	1075	701	866
Elongation at Break, %	ASTM D638	10%	2.20%	6.20%	13.50%	11.70%	5.70%
Flexural Strength, MPa	ASTM D638	40	3	38	31	22	18
Ash Content		0.01%	0.008%	N/A	N/A	N/A	N/A

5 UNPACKING AND SETTING UP YOUR PROJET 1200

CONTENTS

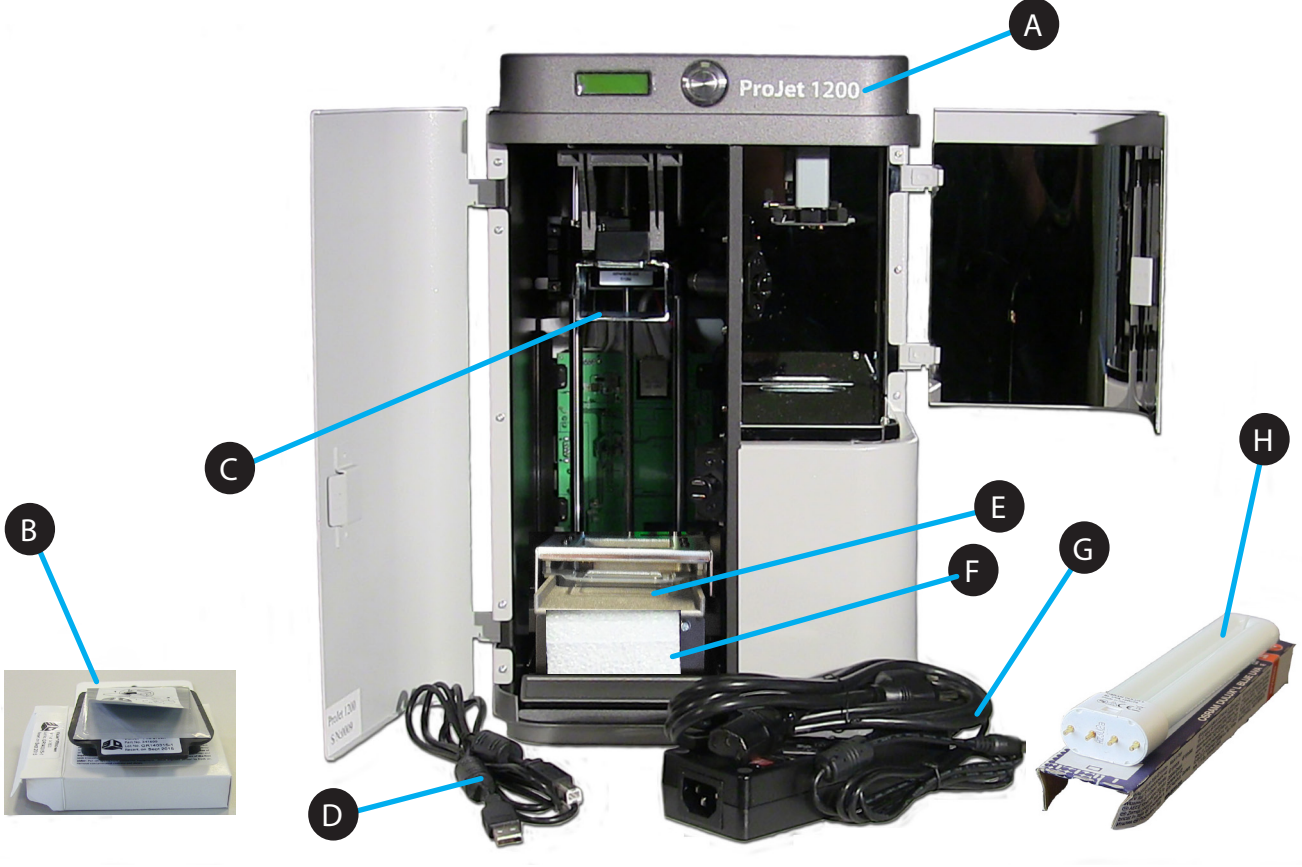

- A ProJet 1200
- B VisiJet® FTX Green Consumable Tray
- C Build Platform
- D USB Cable
- E Plastic Insert
- F Foam Insert
- G Power Supply
- H Curing Bulb

UNPACKING THE PROJET 1200



CAUTION: Ensure that you save all foam and packing material for the future repacking of your ProJet 1200. Shipping the printer without original packing materials may cause damage to the printer.

1. Pull the grip handle tabs (A).



2. Remove the grip handles from the box.



3. Lift the outer box off the printer.

4. Remove the peripherals box (A) and the upper foam insert (B).

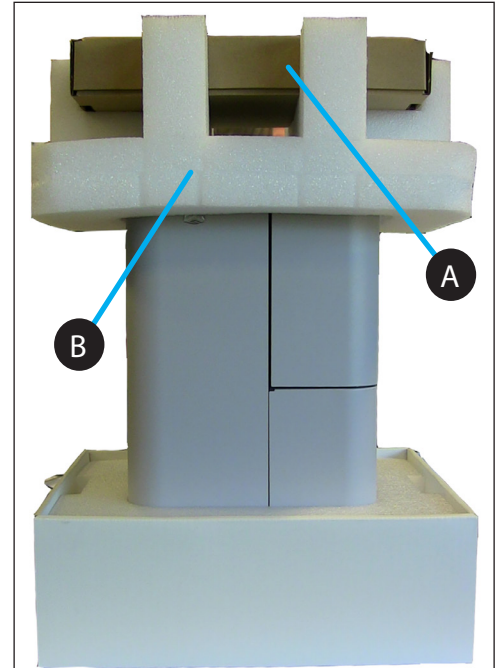

5. Carefully remove the printer from the lower boxed foam support and place it on a solid, level base where it will be used.



CAUTION: Do not install the printer near direct sunlight. If the material cartridge is exposed to direct sunlight, the resin will begin to cure.



NOTE: There should be a utility power outlet and an active network port nearby.



NOTE: There should be a minimum of 6"/152 mm air space between the back of the printer and any other object.



NOTE: There should be at least 10"/254 mm air space on either side of the printer.

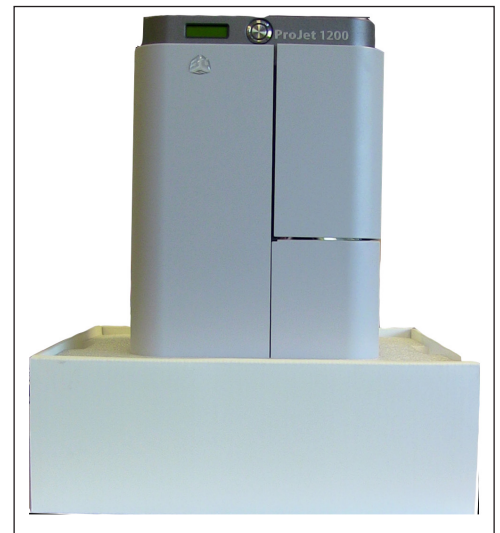

6. Remove the protective film (A) covering the display.

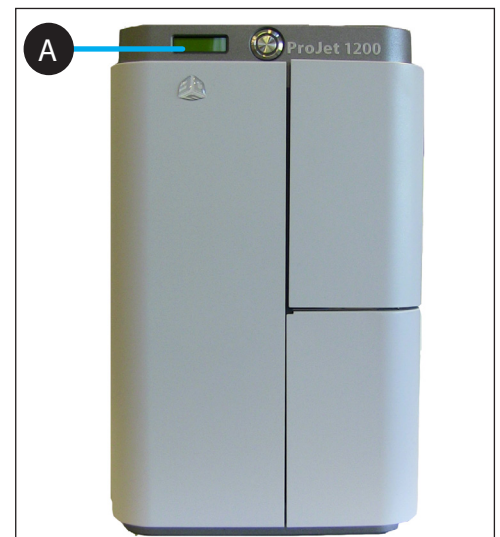

7. Open the peripherals box and remove the USB cable (A), country specific power cord (B), print platform (C), curing bulb (D), power supply (E) and material cartridge (F).



NOTE: Keep the material cartridge away from direct light. UV light will begin to cure the print resin in the cartridge and render it useless.

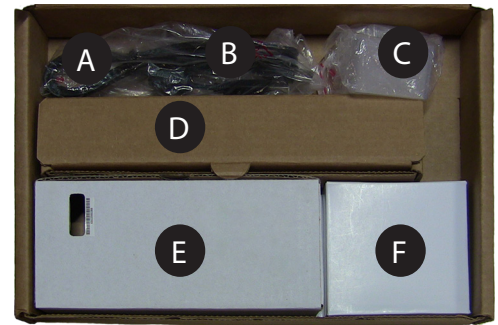

8. Open the print door and remove the plastic insert (A) from the material cartridge support.



NOTE: If necessary, lift the print material cartridge clamp lever (B) to gain more clearance.

9. Remove the foam insert (B) from inbetween the material cartridge support and the clamp lever (C).



NOTE: When installing the UV curing bulb, ensure the plastic insert is reinserted in the material cartridge clamp. The plastic insert is designed to protect the glass pane in the material cartridge support.

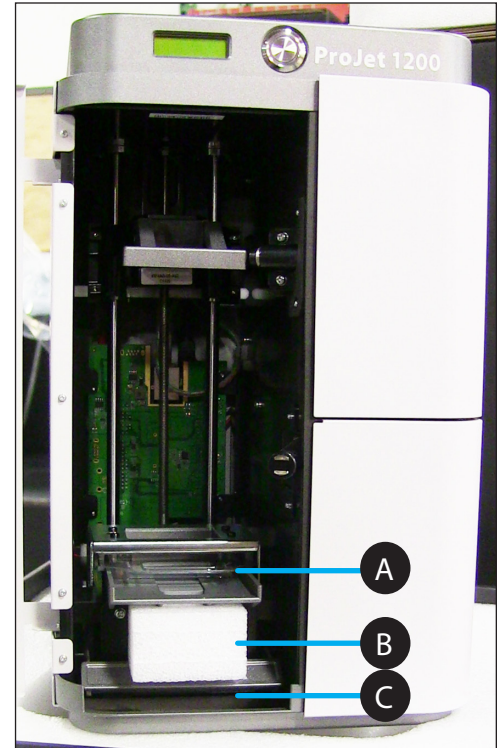

PRINTER SETUP

Installing the Curing Bulb



CAUTION: Do not touch the curing bulb. Keep the protective sleeve on the bulb until after the bulb has been installed.



CAUTION: Exercise caution when installing the bulb. If the printer is rotated to its side or upside down, the glass plane under the material cartridge support assembly may dislodge or become damaged. It is strongly recommended that the packing foam is inserted into the material cartridge support and then the cartridge clamp secured with the material cartridge clamp lever.

1. Open the curing door.
2. Hold the Curing Bulb with tissue paper or paper towel, with notch facing up.
3. Insert end of bulb down in hole and bulb base up into socket ensuring it locks into place.

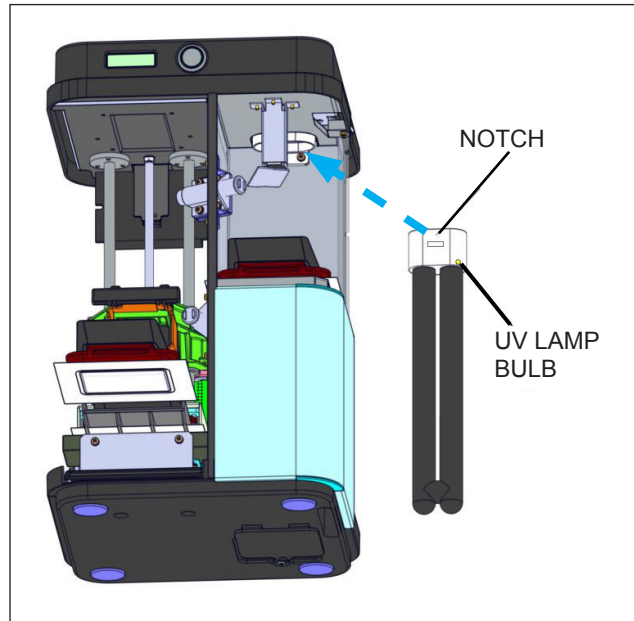

4. Carefully press the bulb base into the socket and ensure the connection is secure.

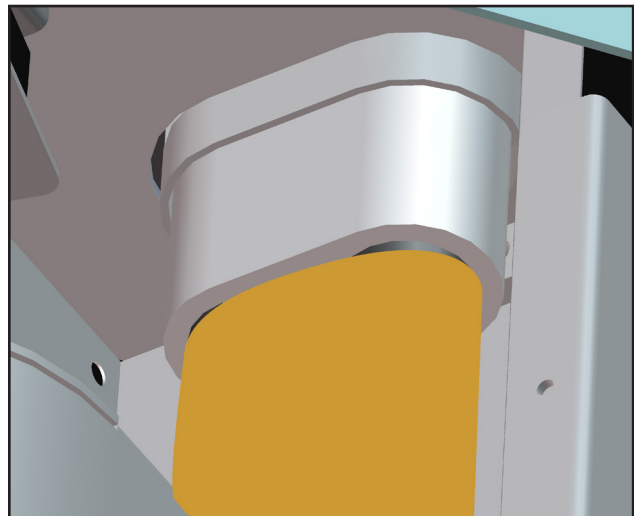

Installing the Material Cartridge



CAUTION: For best results, do not expose the material cartridge to excessive light. Light will begin to cure the material causing it to harden prior to printing.



Always wear protective gloves when installing or replacing a material cartridge.

1. Lift the material cartridge clamp lever (A) up to raise the cartridge clamp.



NOTE: When removing cartridge from foil bag look in bag to ensure there is no resin inside bag. If resin is present do not insert cartridge in the machine. Contact your reseller for a cartridge exchange.

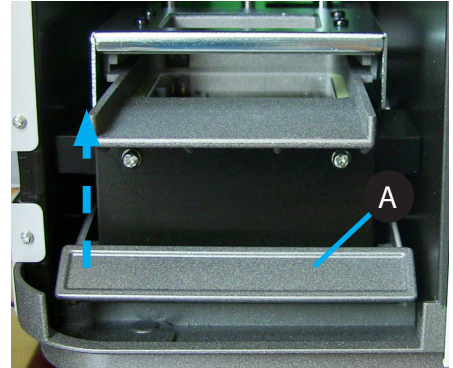

2. Before inserting a new cartridge into machine, be sure to take the alcohol wipe supplied with the new cartridge and completely wipe off the entire cartridge holder as shown.



CAUTION: Failing to wipe away any residual material from the cartridge holder can contaminate any future builds and glass surface.



NOTE: Always wear nitrile gloves when wiping off cartridge holder to ensure no material gets on skin.



NOTE: Before opening FTX Gray, Silver, and Gold cartridges, hold the cartridge securely and shake firmly but carefully for about 30 seconds to mix the contents.

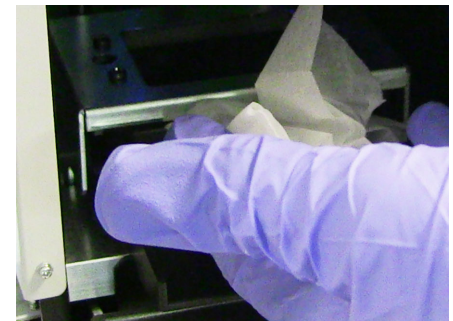

3. Check material cartridge to ensure tab is folded over and facing the front of machine, if not, fold over now.
4. Insert the material cartridge into the material cartridge support and then under the material cartridge clamp.



NOTE: The material cartridge will set into a pocket on top of the glass pane.



CAUTION: If a leak/spill occurs do not run the machine. UV curing will harden it on the window glass and that will make it very hard to remove. A long cleaning swab and isopropyl alcohol will help clean up any spilled resin.



CAUTION: It is very important that the cartridge be seated correctly in the pocket or else a leak can be created in the cartridge which may damage the system.



NOTE: For machines that were manufactured before 6/12/14 Glass Frame Assembly will look like photo at right.

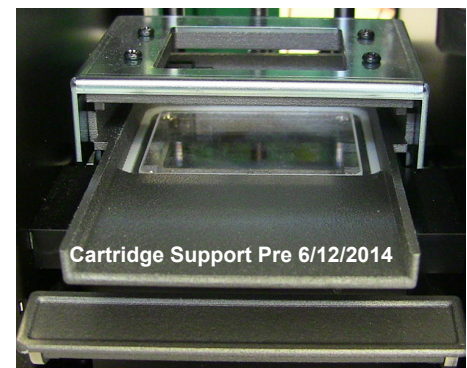



NOTE: For machines that were manufactured after 6/12/14 Glass Frame Assembly will look like photo at right.



NOTE: To remove this new Glass Frame Assembly from the Cartridge Support insert finger in hole of support and pull the glass frame assembly out.

Glass Frame Assembly Post 6/12/2014

Cartridge Support Post 6/12/2014

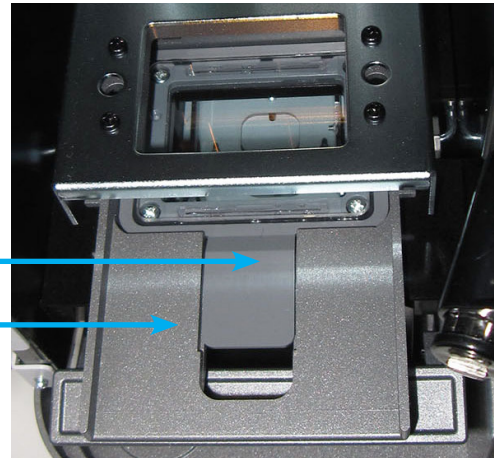

5. Rotate the material cartridge clamp lever (B) down to lower the cartridge clamp (A).



NOTE: Ensure the clamp is locked. If the clamp requires a lot of pressure to lock, check that the cartridge is seated properly in the pocket.



NOTE: FTX Gray, Silver, and Gold may need to be stirred for best results. Common issues from unstirred material include nonuniform color or shine, build failure from parts falling off the platform, or warped or missing features. For FTX Gray, Silver, and Gold, regularly check the material while the cartridge is in use. If the color of the parts starts to change or the material begins to separate, put on nitrile gloves and carefully stir the material with a gloved finger with the cartridge locked in place, being careful not to slosh or drip material inside the printer. If you still do not get satisfactory results, put on nitrile gloves and carefully remove the cartridge from the printer. When the cartridge is outside of the printer place it on a flat clean surface before stirring so as not to distort the film or push against the seal. Gently stir the material with a gloved finger, being careful not to scratch or dent the cartridge film or spill material onto the sides or top of the cartridge. When the material appears homogeneous, carefully remove the stirring finger to avoid dripping material and slide the cartridge back into the cartridge support. Make sure the cartridge sets securely into the pocket and push down the clamp to lock in place.



NOTE: It is important to only remove cartridge when necessary. Repeat clamping can break the seal between the film and the cartridge.



NOTE: When the cartridge is successfully installed, the LCD screen will display the material type contained in the cartridge. This will eliminate the need to select Check Cartridge.

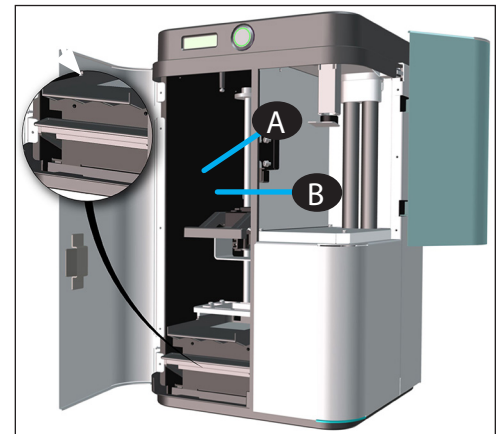

6. Once this message appears, you can carefully pull back the label.

Installing the Print Platform



Always wear protective gloves when handling the print platform.

1. Rotate the print platform clamp lever upward.

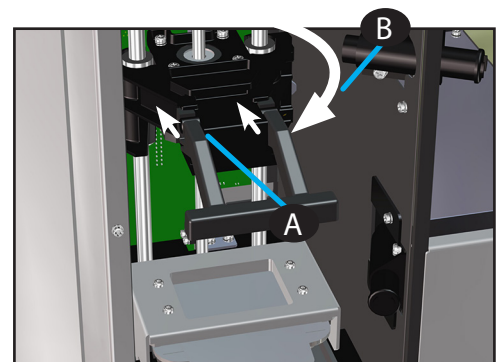

2. Insert the print platform under the clamp lever until it is seated (A).
3. Rotate the print platform clamp lever down to lock the print platform (B).

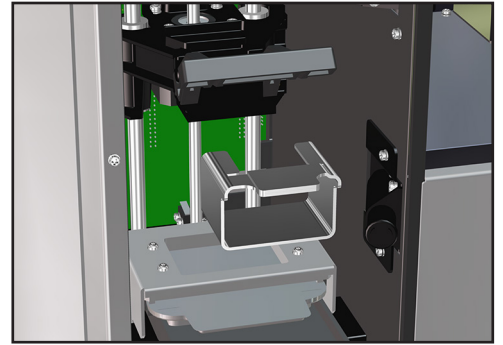

6 SYSTEM REQUIREMENTS

	Minimum	Recommended
OS	Windows 7 (64-bit) Windows 8 (64-bit)	
CPU	Intel® or AMD® processor with a minimum of 2.0GHz	Multiple core processor. Hyper-threading and clock speeds above 3GHz can be beneficial but should be paired with a good balance of cores.
RAM	4 GB	8 GB or more Virtual Memory in Win 7 and Win 8 it is recommended to use the default option; "Automatically manage paging file size for all drives"
HARD DISK	30GB of hard disk space for cache. Temporary file cache requires about 3 GB free disk space for every 100 million points	SSD or 10,000RPM HDD
Display/GPU	Open GL 2.1 and GLSL 1.20 enabled graphics card. Screen resolution 1280x960	OpenGL 3.2 and GLSL 1.50 enabled graphics card NVidia or AMD GPU with 1GB of RAM or more. Screen resolution 1280x1024 or higher
OTHER	3 button mouse with scroll Keyboard Internet connection Explorer 9 or newer. Microsoft .NET Framework 4.5 (installed with application)	Google Chrome or Internet Explorer 11

POLYGON MESH

File Extension	File Format	Features
.stl	binary STL	Import, Export parts
.ctl	CTL	Import, Export parts
.obj	Object	Import, Export parts
.amf	Additive Manufacturing File Format	Import, Export parts
.ply	CyberWare Binary	Import parts
.zpr	3DSYSTEMS format	Import parts
.wrl	VRML file	Import parts
.3ds	.3ds file format	Import parts

Create Account

Type <https://3dscentral.3dsystems.com> in your browser. You will need to create an account (your email will be used as the User ID) and choose an easy to remember password (1). Your printers serial number appears on the backside of the machine. After registration an email will be sent to you with a link to the 3D Systems 3DS Central login page.

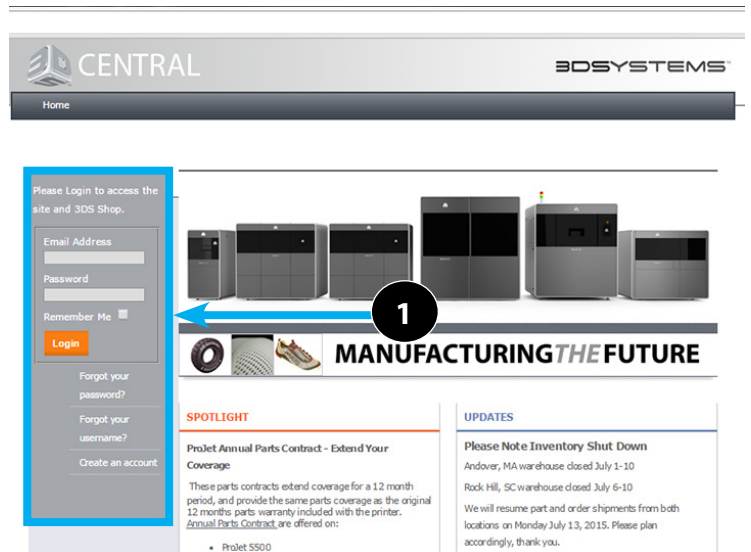

Installing the 3DSPRINT™ Software

3DS Central is the location where you can access user manuals, installation guides, service procedures, software and firmware information. You must create an account to gain access to these resources.

1. Go to <https://3dscentral.3dsystems.com> and enter your name and password (2).



2. Select **Products** (3).

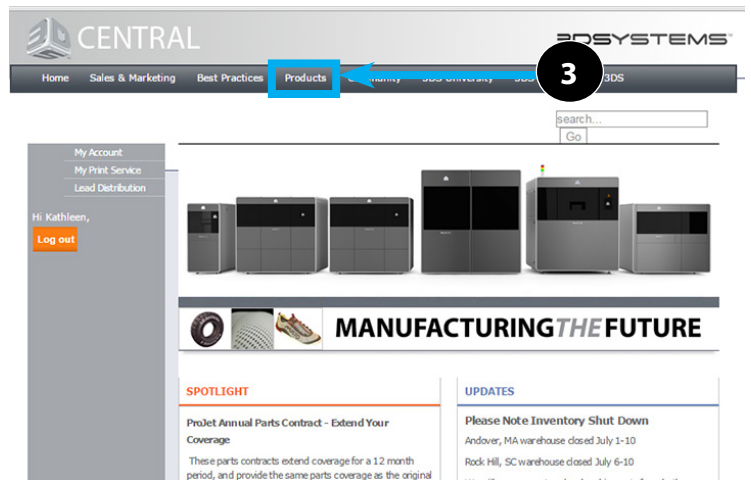

3. Select **Professional 3D Printers** (4) from the left navigation bar.

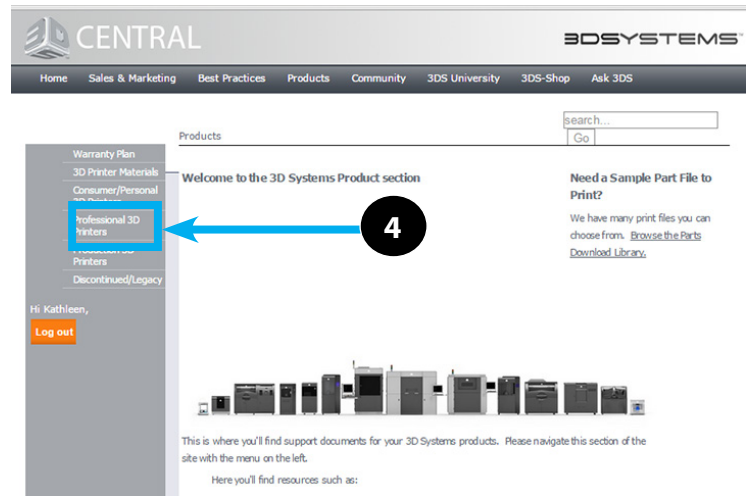

4. Select **ProJet 1200** (5) from the drop-down menu.



5. Download the application software by selecting the filename under the software header (6).



NOTE: A window may open asking if you want to open or save the zipped file. Select your preferred option.

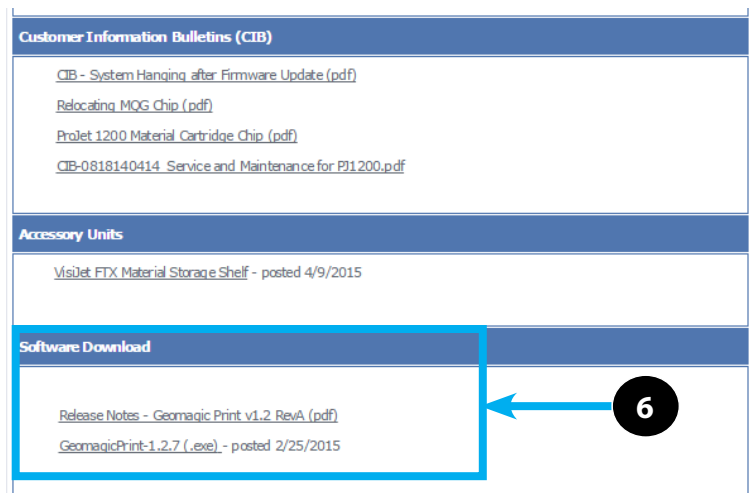

6. Double-click file that was just downloaded to begin installing software.

Install Application

1. Open the downloaded installer.
2. The first screen to appear in the download process is **Calculating Information** screen.
3. Select **Next**
4. The next thing that will appear is the license agreement. Carefully read the license information and select:
I accept the terms in the License Agreement
5. Select **Next**.
6. This screen will allow user to select the path for the information to be stored.
 - A. If the default path is sufficient, select **Next**.
 - B. If user wishes to select somewhere else, select **Browse** and navigate to the selected path, select **Next**.

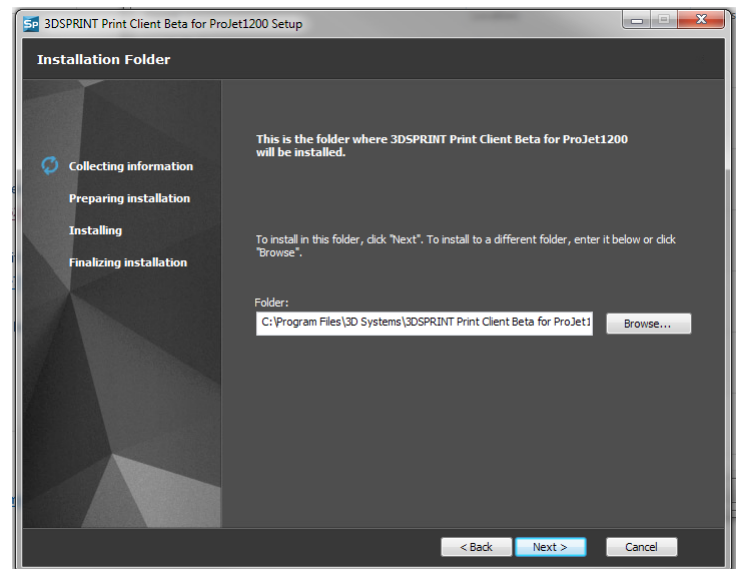
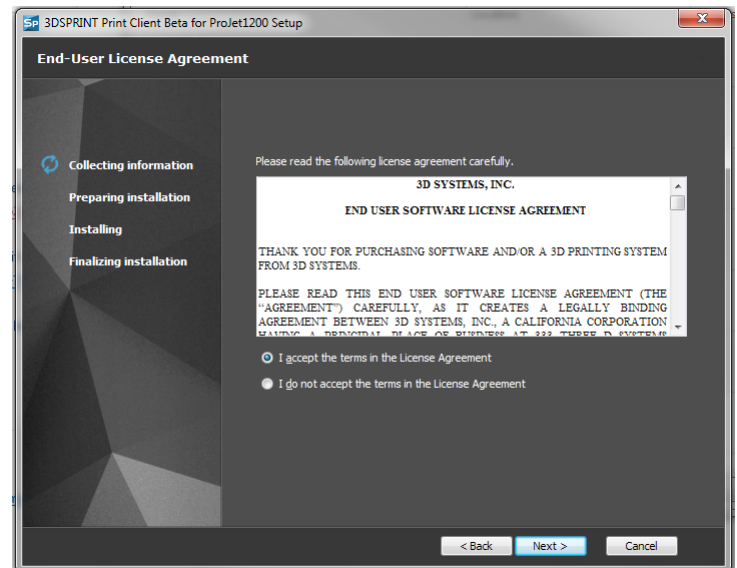
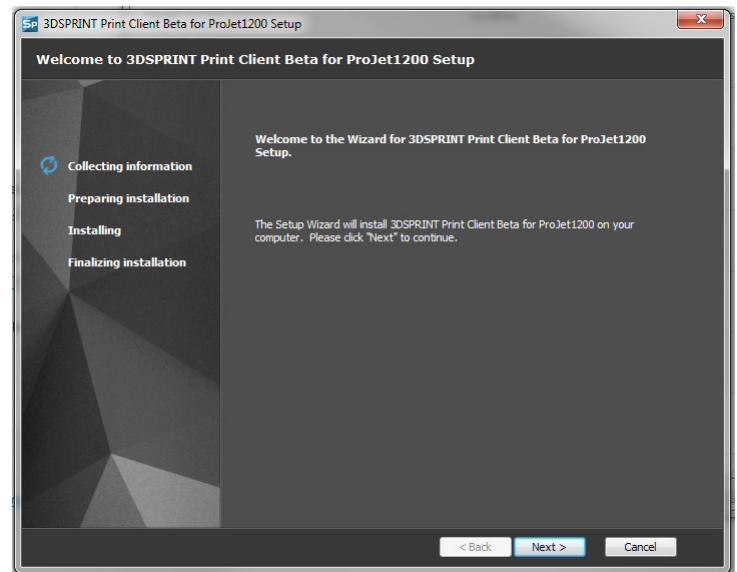

7. The **Preparing Installation** screen is next. Select **Install** when this screen appears.

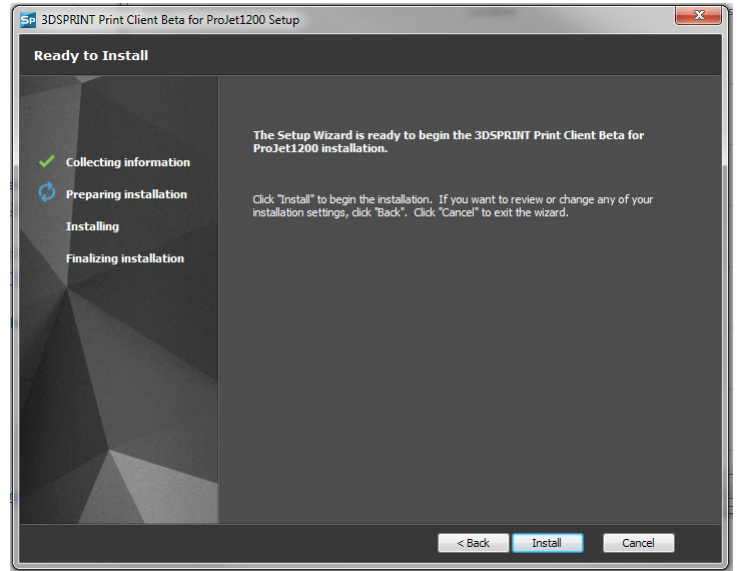

8. The Installation screen appears with a status bar at the bottom of the left pane displaying the status of the installation. When bar is completely green, the next screen will appear.

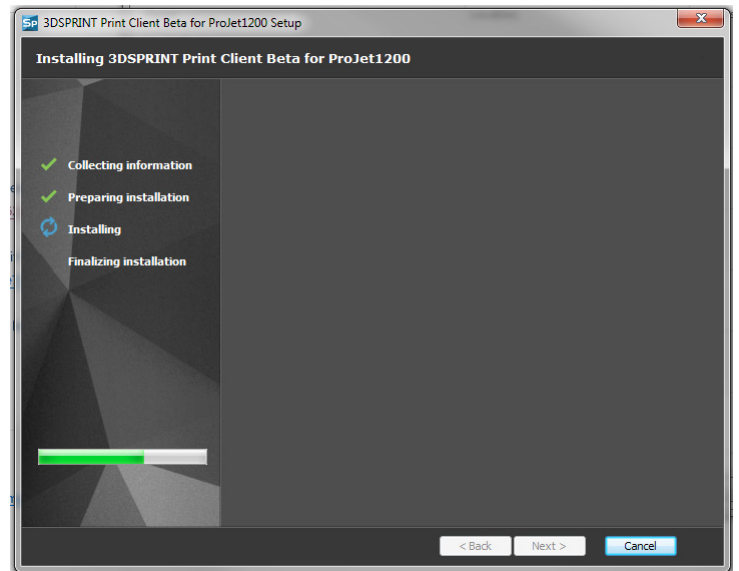

9. The next thing you will see is the 3DSPRINT Profiler screen.

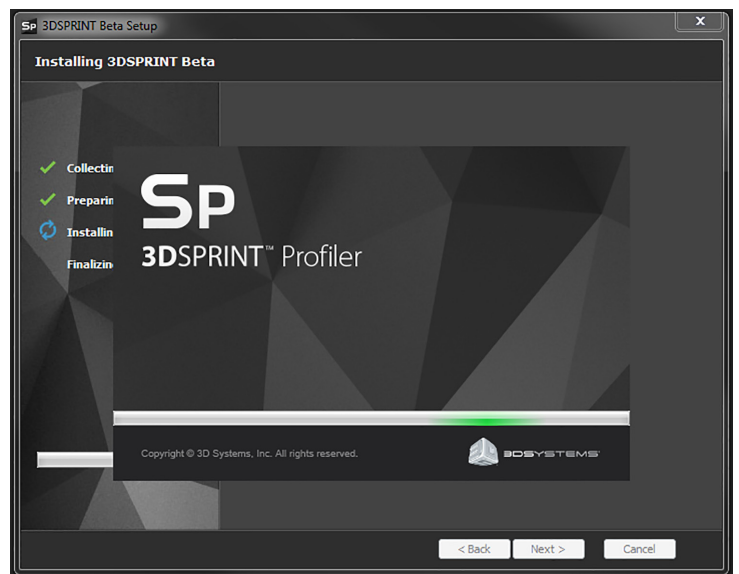

10. A box will pop up asking if you want to send information to 3D Systems anonymously that will allow improvements to the software based on the data it receives. If you wish to allow this, click **Yes**.

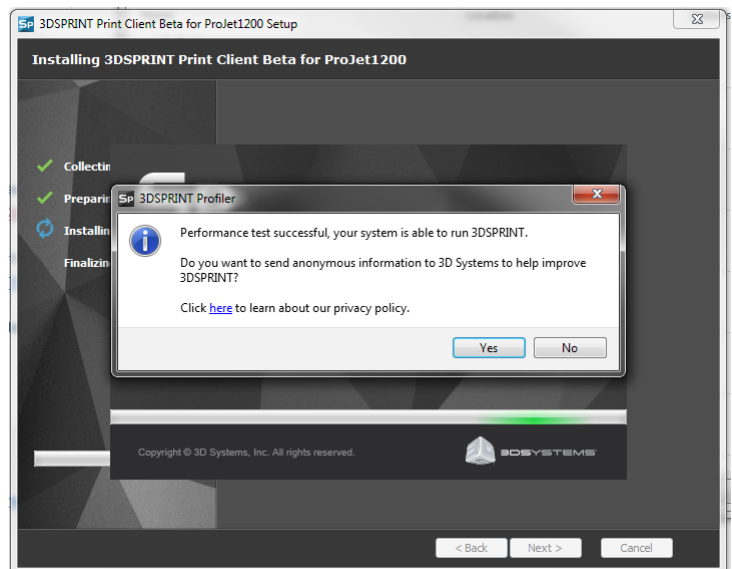

11. If you select Yes a thank you box will appear. Click **Close**.

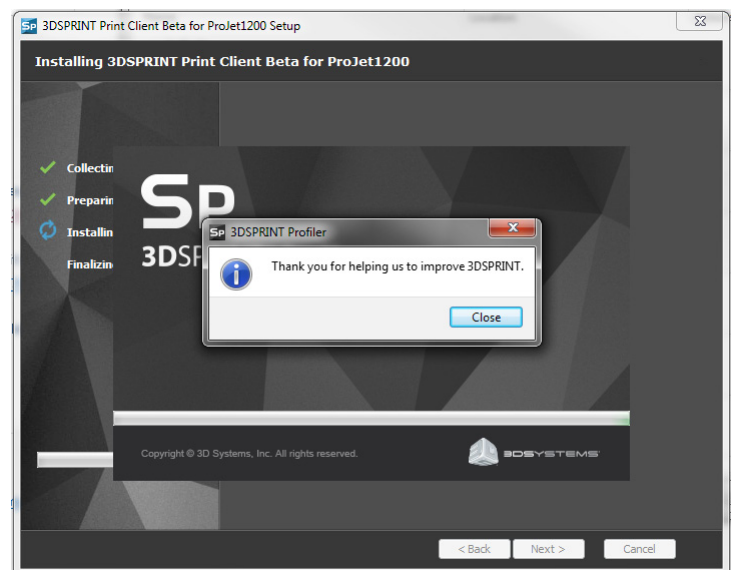

12. The last step in the process is when the **Finalizing Installation** screen appears, at this point select **Finish**.
13. Installation is now complete.

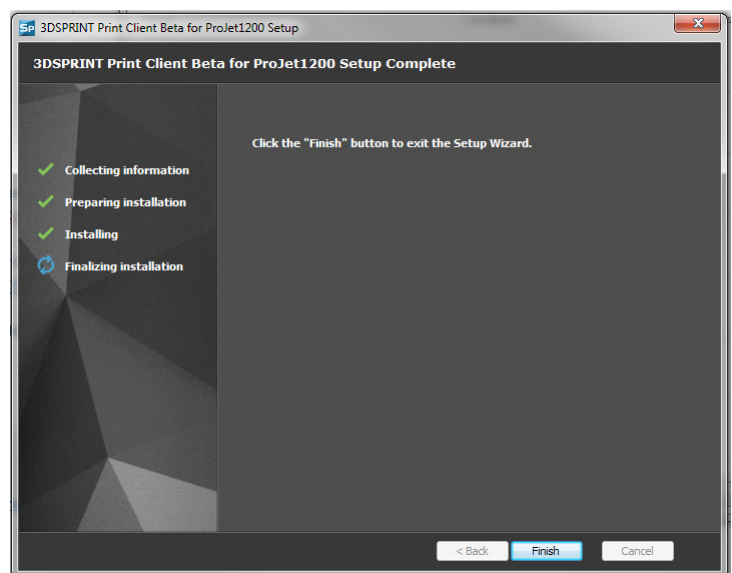

Checking for Updates

Every time the application is launched it will check for updates, if updates are available, a dialog box will appear guiding the user through the installation.

How to Use

1. If updates are available at launch of application, this dialog box will appear.

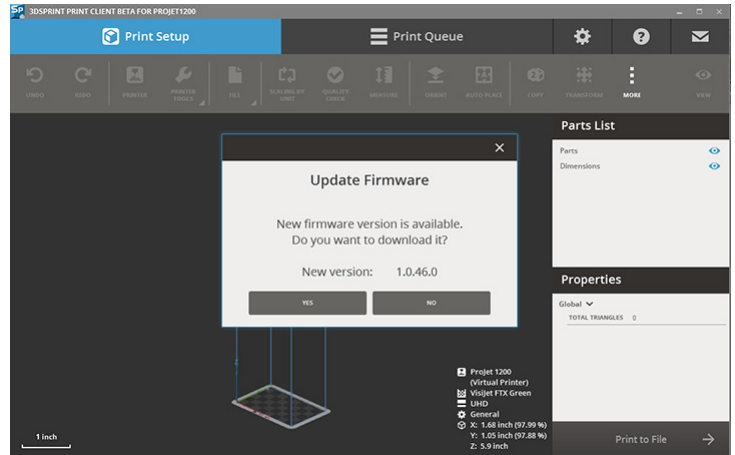

2. Click **Yes** to update.
3. Download will start.
4. After the download is completed the installer will open.
5. Follow the installation steps to complete the update.



NOTE: All files and user settings will remain after updating the application.



Connecting The Printer

The printer is network-ready and easily connected.

1. Connect the A/C power cord to utility power and then connect the power supply to the power inlet (A) on the printer.



WARNING: DO NOT PLUG IN USB CABLE AT THIS TIME. ONLY PLUG IN USB CABLE AFTER DRIVERS ARE LOADED AND MACHINE IS BOOTED, SEE USB INSTRUCTIONS IN FOLLOWING SECTION.



NOTE: After connecting the printer to utility power, a series of screens will appear as the printer boots up.



NOTE: This screen shows the firmware version number.



NOTE: This screen indicates that it is not connected to a network.



NOTE: This screen shows that the printer has completed the boot process and is ready to connect to a network.

2. If connecting to a network, connect the printer Ethernet port (A) to the network with an Ethernet cable. If connecting printer via USB connection see [CONNECTING PRINTER USING USB CONNECTION](#) below.



NOTE: Once the printer is connected to the network, the IP address will appear.



NOTE: If no IP address displays this could be because your company is on a sub net. Contact your IT Administrator for the IP Address.

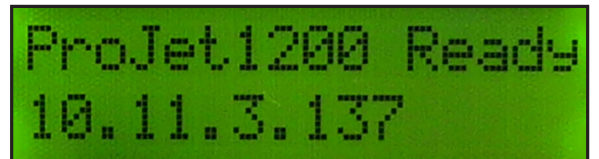
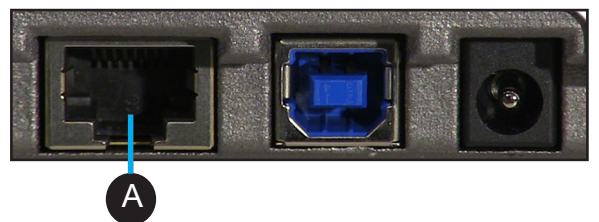
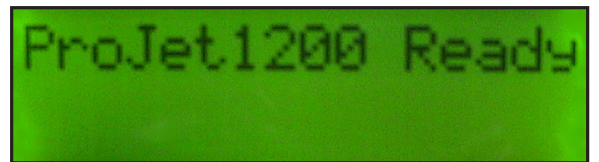
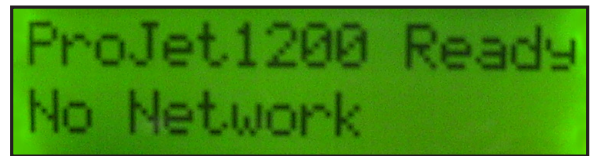
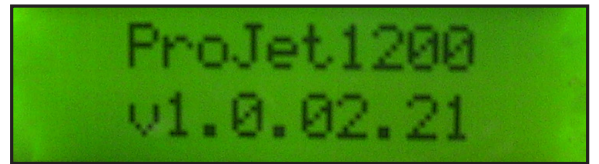
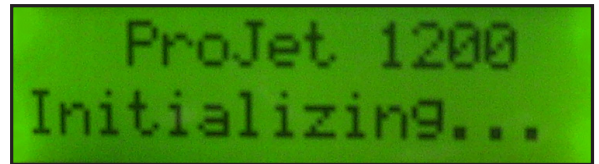
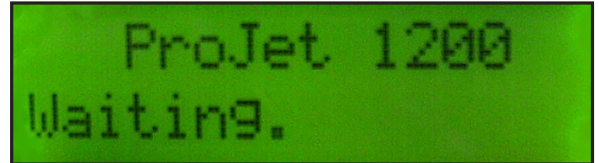
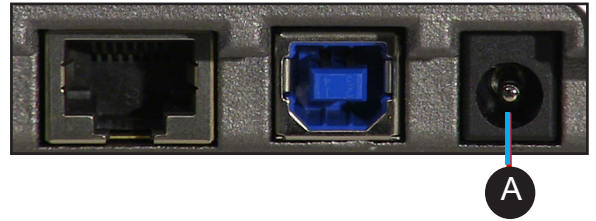

Connecting Printer Using a USB Connection

Follow Step 1 above, when LCD display shows **ProJet 1200 Ready** connect machine via USB cable and wait while machine installs all the necessary drivers for that particular printer on your computer. (This will take a couple of minutes).

Once updates are complete, and printer is connected, display will show the **Printer Ready No Network**.

Selecting Printer for Project

The 3DSPRINT Software allows the user to select from several different printers depending on what type of job will be printed. Any printers that are running the 3DSPRINT software can be networked to the software allowing user to select the particular machine they need at any particular time.



NOTE: If you are connecting to a new printer you must first activate it. Follow these steps to activate your printer first.

Activating Printer

Before using a printer for the first time, it needs to be activated. This process is completed when using the printer for the first time in 3DSPRINT.

How to Activate Printer

1. Send a print job to the printer or run **Post Cure** command.
2. If the printer is not yet activated, a dialog will appear requesting user information for activation.
3. Complete the form except Service Code and click **Next**.



NOTE: An internet connection is required to activate the printer.

4. The printer will now be activated through the 3DSystems activation server.
5. Print or post cure will continue as normal.

If problems occur during the process, please contact your local reseller.

Set Current Printer

1. Double-click the 3DSPRINT Software icon on your desktop.
2. Select **Print Setup** (1) on the main screen.
3. Select **Printer** (2).

4. Click on desired printer
5. Click **Next** (3).

Activation

The printer is not activated, please fill in all information and click OK to activate the printer.

Serial Number:

First Name:

Last Name:

Company:

Email:

Phone:

Country:

For resellers or internal use only

Service Code:

OK

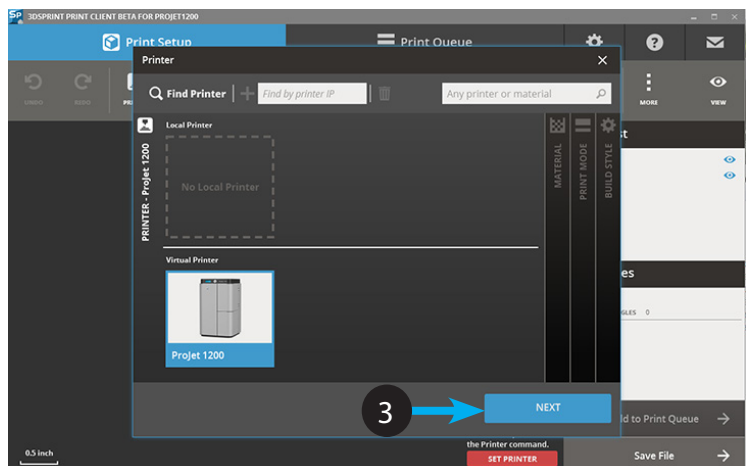
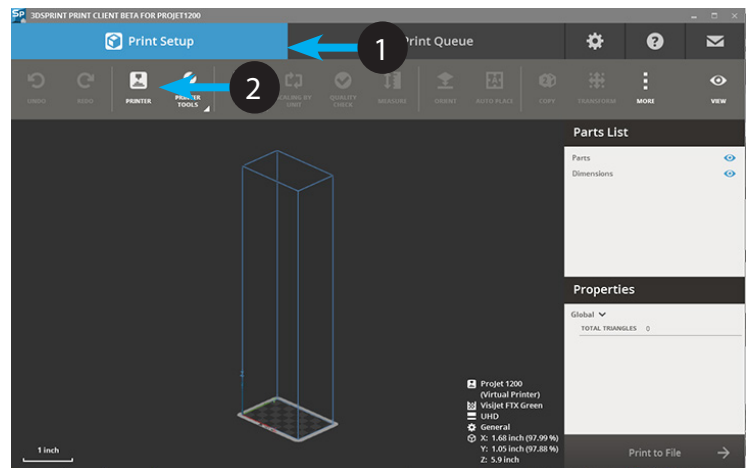

- If the material currently loaded is different than what is desired, you must select the **Loaded Material** (5) and click **Unload**. If there is no material currently loaded, user can double-click desired material and it will be loaded.
- Click **Next** (6).



- Select **Print Mode** (7) and click **Next** (8).
- The application workspace will be set according to the selected printer.

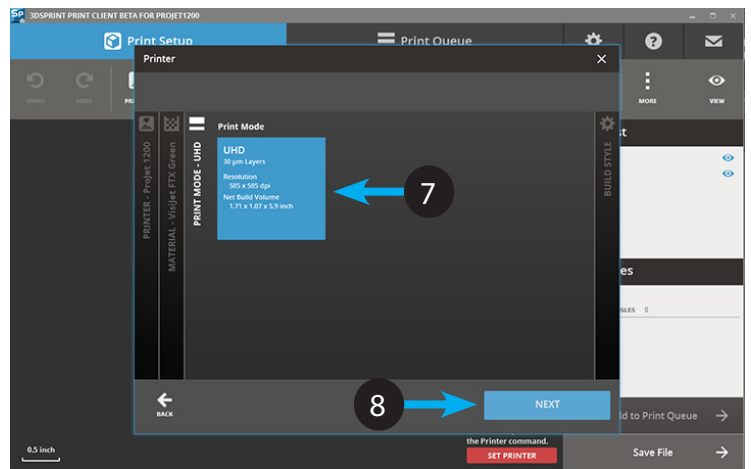

- The next thing to select is the **Build Style**(9). Select the desired build style and click **Set** (10).

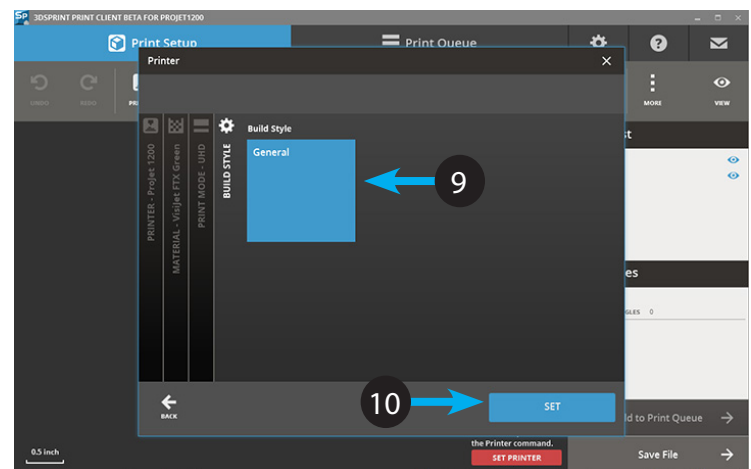

Add a Printer

- Printers on the network will be automatically added, if the printer is not detected enter the IP address of the printer.
- Click **+**.

Add a Virtual Printer

- Select one of the virtual printers shown in the bottom of the dialog box.
- Click **Next**.

Remove a Printer

- Select the printer you wish to remove and click on the Trash Can.

When printer has been added, material and mode is selected, there should be an **Information** (1) window showing on the screen displaying the basic printer information.

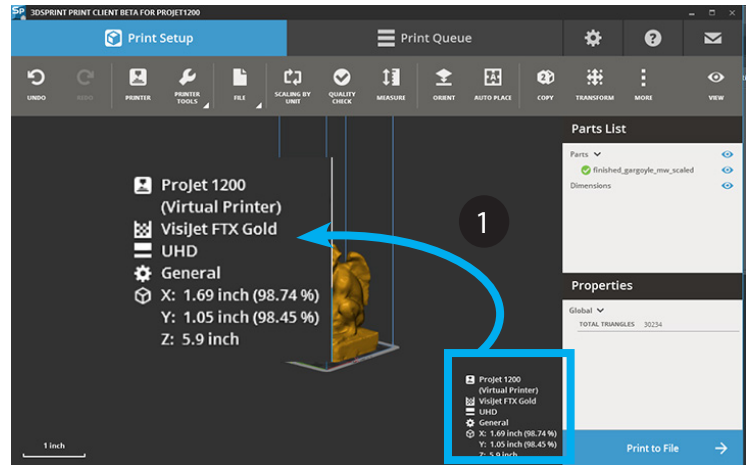

Test Post Cure

The **Test Post Cure** command enables the curing chamber for about 10 seconds. The UV light bulb will light up and the carousel will spin. It is used to test the curing chamber of the carousel printer.

How to use:

1. Test the connection by selecting **Test Post Cure** (2) from the **Printer Tools** (1) Tab.



NOTE: The curing chamber carousel should rotate if the printer is connected. The curing door must be shut to perform this operation.



WARNING: DO NOT OPEN THE DOOR TO THE CURING CHAMBER WHEN THE ULTRA VIOLET (UV) LIGHT IS ACTIVE. USE RECOMMENDED PROTECTIVE EYE WEAR.

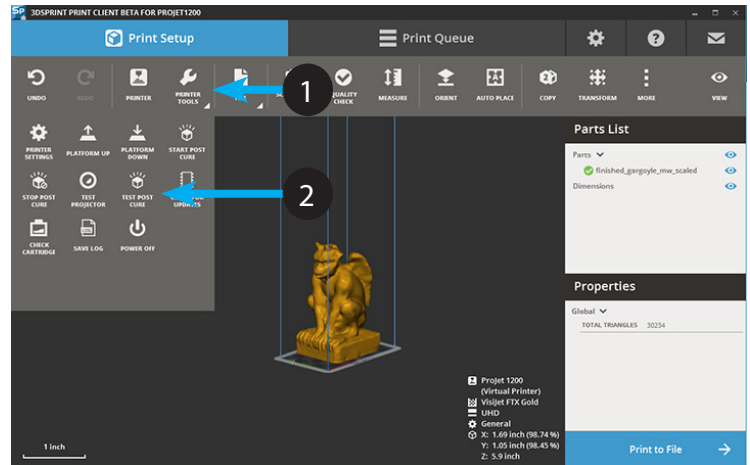

Check Material Cartridge

Before removing label from material cartridge, test to ensure cartridge is inserted properly.

1. Select **Check Cartridge** (2) from the **Printer Tools** (1) tab.
2. If cartridge is not inserted properly an error will occur.

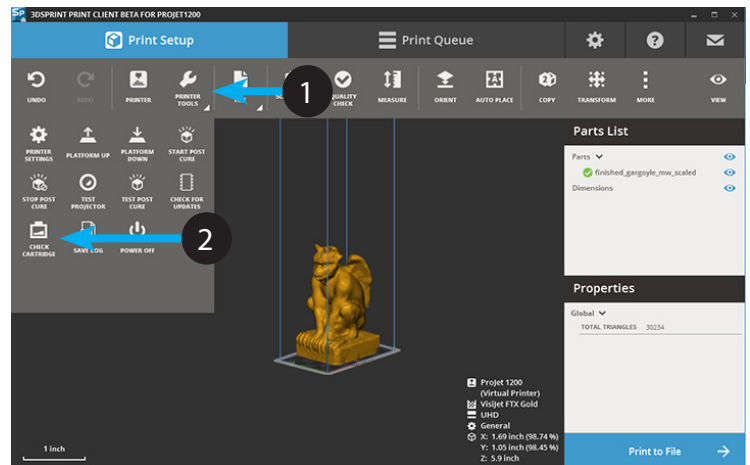

- If cartridge is okay, a window will pop up letting user know how much material is left in cartridge. When new it will say 100%.
- Once cartridge is determined to be okay, you can carefully pull back the label.



NOTE: Do not move the machine with the cartridge inside once it is opened.

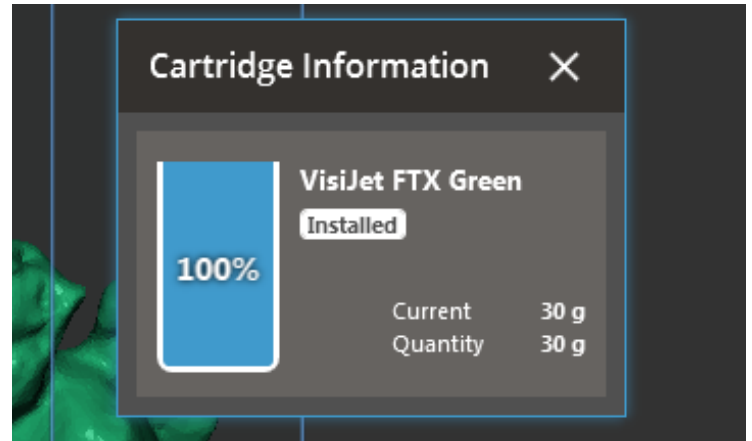

Platform Up

The **Platform Up** command moves the printer's platform up to the highest position. It is used to test the platform of the current printer.



NOTE: If the platform is moving down, platform will directly change direction and move up.

Platform Down

The **Platform Down** command moves the printer's platform down to the lowest position. It is used to test the platform of the current printer.



WARNING: MAKE SURE THE PRINT PLATFORM IS CLEAN AND EMPTY, IF THERE ARE PARTS LEFT ON THE PLATFORM THE PRINTER MAY BE DAMAGED.

Post Cure

The **Post Cure** command starts or stops the post curing process.

The first time a printer is used, it is required to activate the printer. In that case a dialog box will appear requiring user activation. Please see **Activate Printer** for more information

How to Use:

- In the **Print Setup** module, open the **Printer Tools**.
- Click **Post Cure**.
- Post curing process will start.



NOTE: Post curing can also be started by pressing the button on the front of the printer. Press the button again to stop, the printer's display will show the current state of the printer.

Test Projector

The **Test Projector** command enables the printer's projector for about 10 seconds. It is used to test the projector of the current printer. It is also used to test the connection to the printer.

How to use:

- In the **Print Setup** module, select the **Printer Tools** group, click **Test Projector**.



NOTE: To prevent accidental curing of the resin, this command can only be used if there is no cartridge installed in the printer.

- On the printer's printing platform, check that the projector lights up.



WARNING: BE CAREFUL WITH ULTRA VIOLET (UV) RAYS, SINCE IT MAY DAMAGE YOUR EYES. USE RECOMMENDED PROTECTIVE EYE WEAR.

Update Firmware

Firmware will be checked every time 3DSPRINT is launched. See [Check for Updates](#) section.

Updating Firmware Through the 3DSPRINT

You can also check for firmware updates through 3DSPRINT.

1. To check for updates select **Printer Tools** (1) from the command line.
2. Click on **Check for Updates** (2) from the displayed menu.

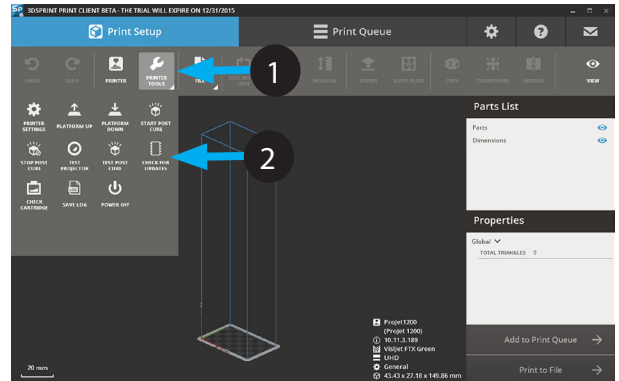

3. If there is a newer version of firmware a message will appear allowing you to update it at this time, if not, you will see the message **Printer Firmware is up to date** (3).

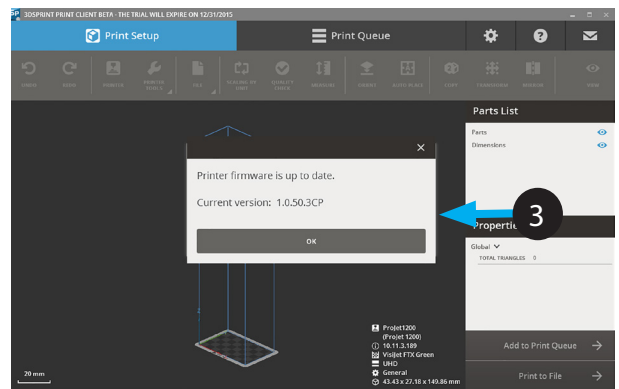

7 OPERATING THE PRINTER

Application overview. The main menus for 3DSPRINT are shown here. For an in-depth instruction on how to use 3DSPRINT select the  icon to launch the Help menu. This will provide a complete instruction on using the software. In this chapter you will learn how to print a part using the basic functions of 3DSPRINT.

SOFTWARE OVERVIEW

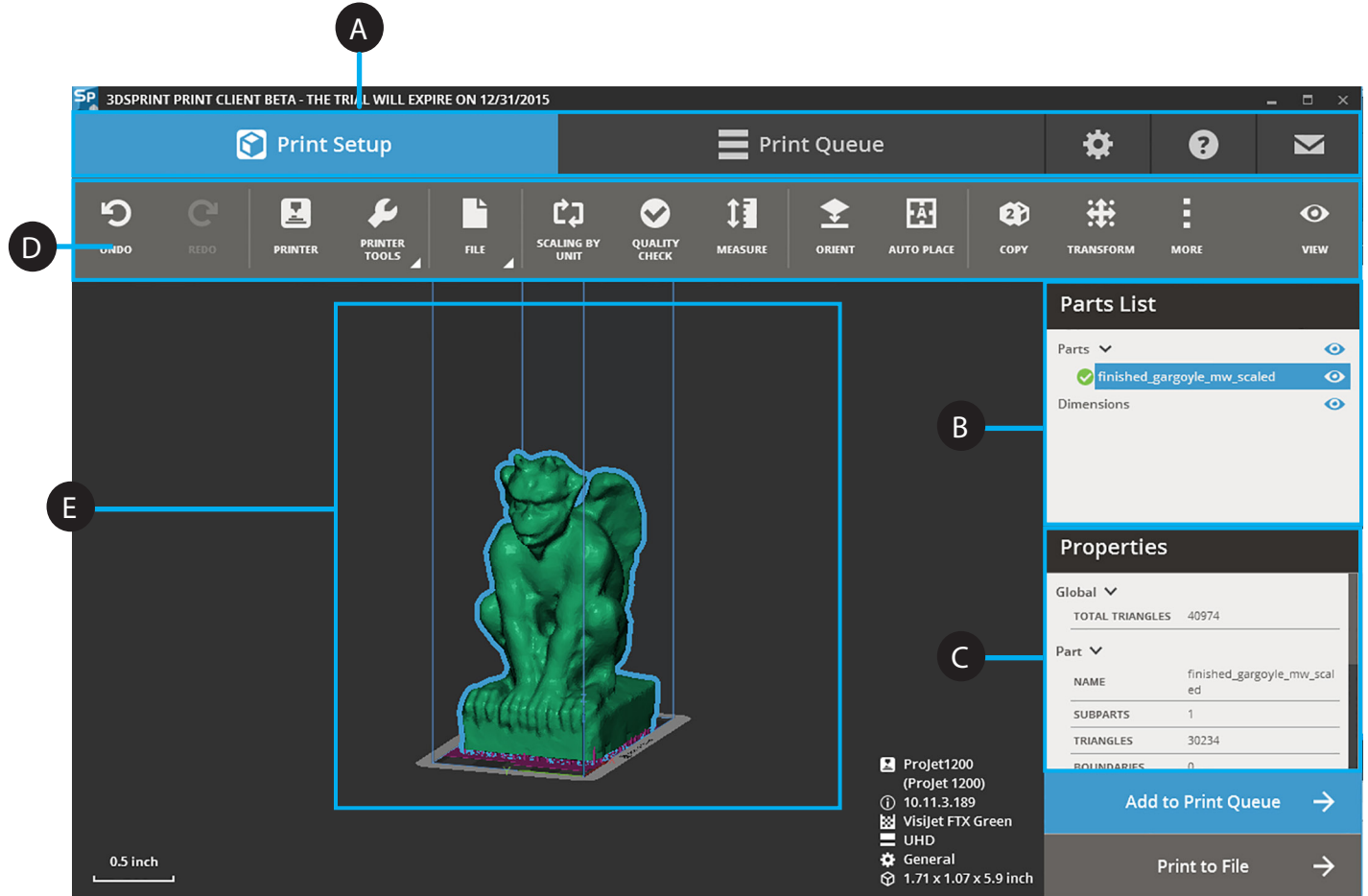

-  Main Modules
-  Parts List
-  Properties
-  Command Bar
-  Print Area

PRINTING A PART

Now that you are familiar with the various screens within the 3DSPRINT software, you can now print your first part. Follow these basic steps to print your first part.



NOTE: Ensure print platform is installed prior to printing a part. See [Print Platform Installation Page 35](#) for more information.

Launch 3DSPRINT

Double click the 3DSPRINT icon on your computer/laptop or select it from your list of available programs loaded on your computer.



NOTE: It is a good practice to click on the **Settings Tab**  in the upper right corner, to check the units of measure before you begin to ensure you have the correct units of measure selected.

Selecting Printer, Material, and Print Mode

1. If you have not already done so, you must select the printer you wish to print on. Click on **Printer** (1) from the **Command Line**.
 2. A list of available printers will display. Find the printer you wish to use (2), select it, and click **Next** (3).
3. Next you need to select the material for the print. Double-click on the desired material (4) and select **Next** (5).



NOTE: If you do not see the printer you wish to use, you can refresh the screen by selecting the arrows beside the **Add Printer** field (4) or if you know the IP address of the printer, you can type it in the **Add Printer IP** field and click +



NOTE: If a material is already loaded and you want to switch you must first click on the loaded material (6) and select **Unload**. You can then **Double-click** on the desired material and select **Next**.

4. Select the **Print Mode** by clicking on the desired mode (7) and select **Next** (8).

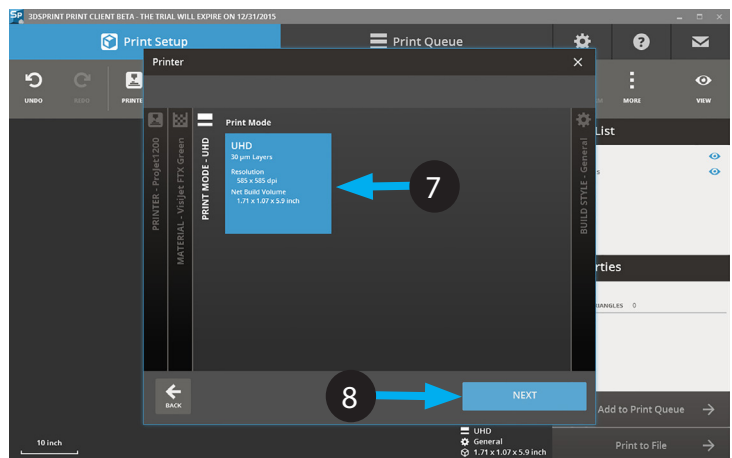
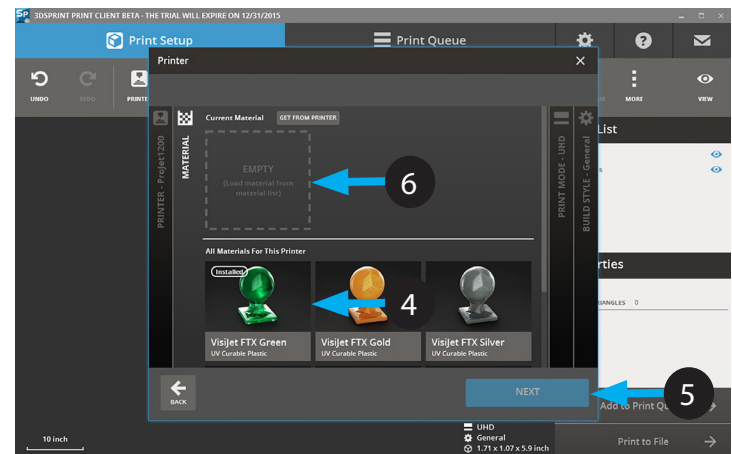
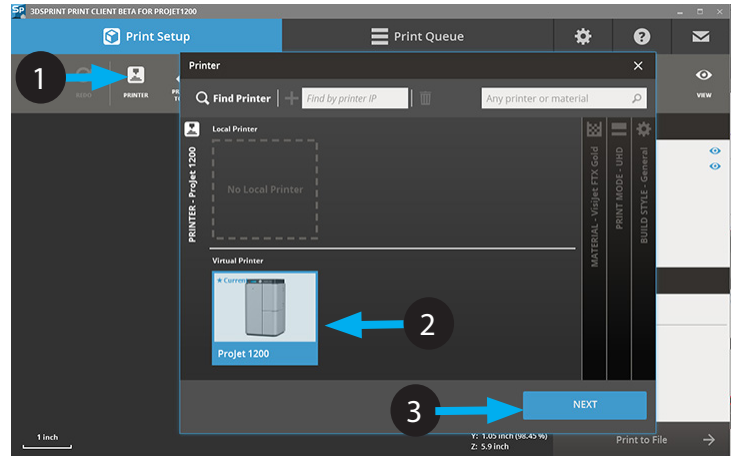

- Finally you must select the Build Style. Select the desired build style (9) and click on **Set** (10).

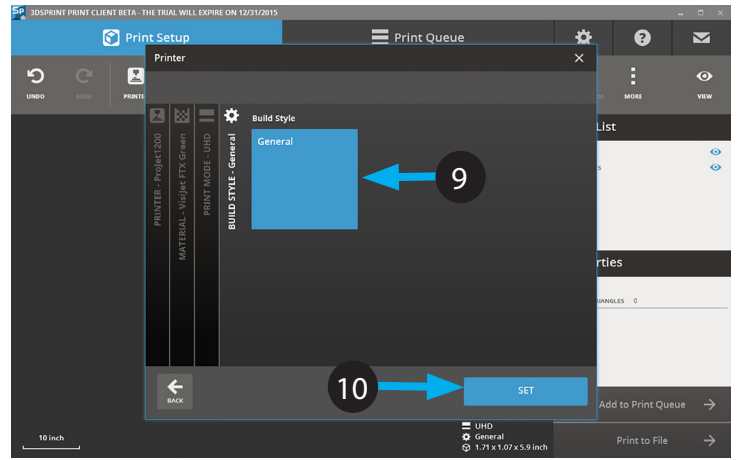

Printing a Print

- Import your file by selecting **File** (1) from the Command Line and clicking on **Import** (2).

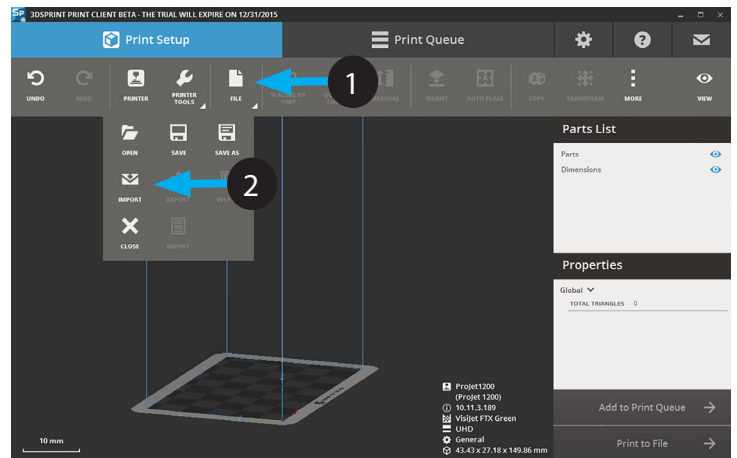

- Navigate to the file you want to print and select **Open** (3).

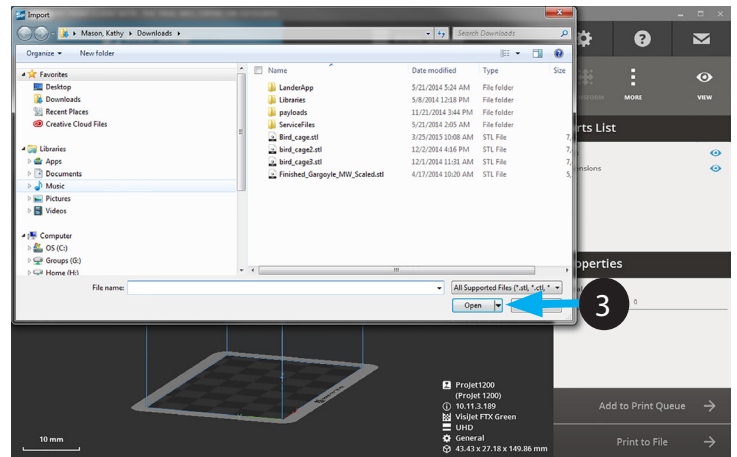

- File will open, but it will not be placed on the platform yet (4).

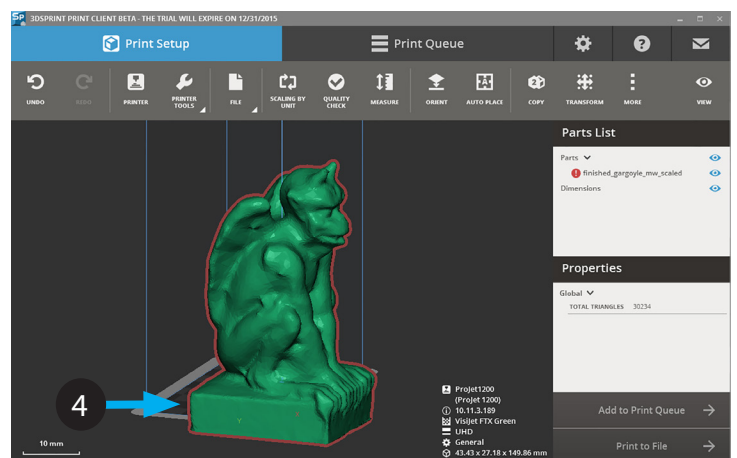

4. Select **Auto Place** (5) to place the print on the platform, select **Set** (6).

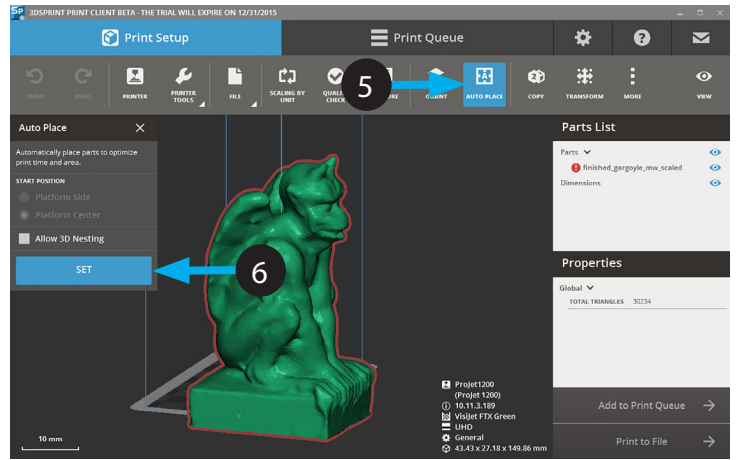

5. When file has been auto placed on platform, you will need to add supports. Select **More** (7) from the Command Line, click on **Support** (8).

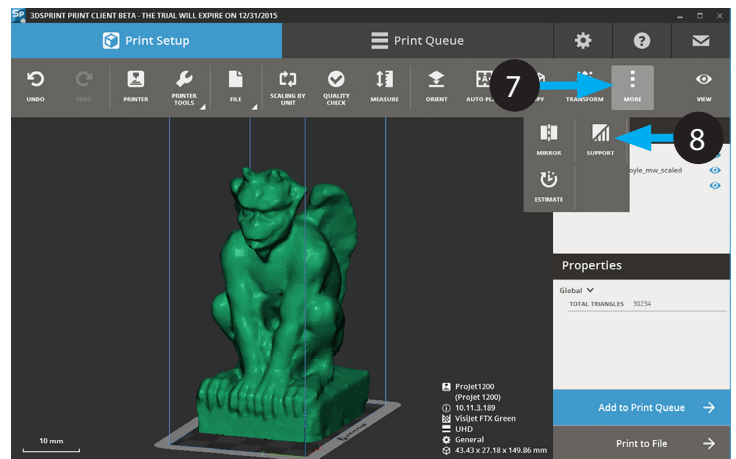

6. Next select **Generate** (9) to begin creating supports for your part.

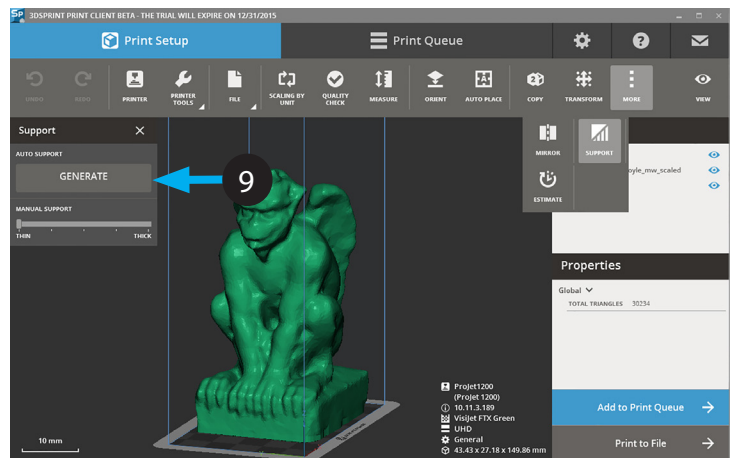

7. **Status Bar** (10) at bottom displays as supports are being generated.

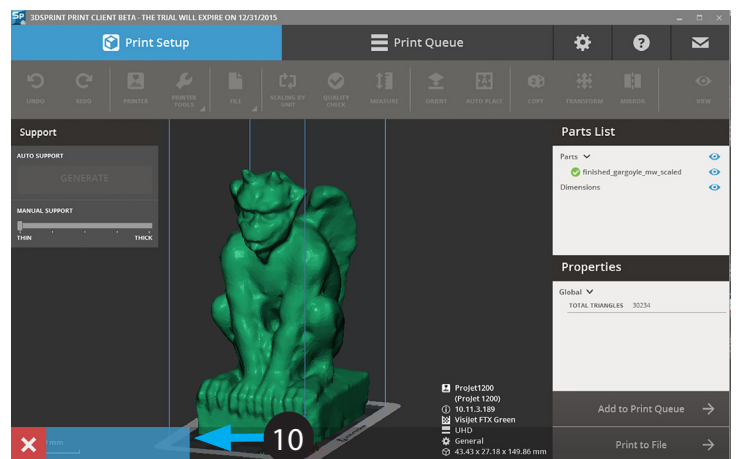

8. After supports have been added, select **Add to Print Queue** (11).

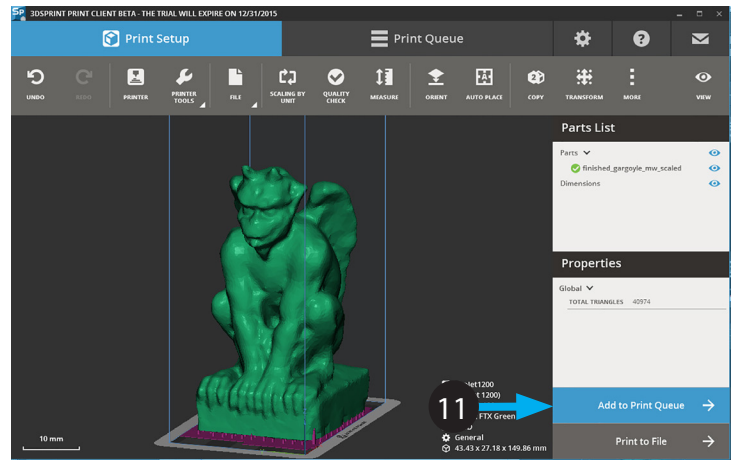

9. Job now displays in the **queue** (12) select the **Play** (13) button to begin printing.

10. If job was sent by mistake or needs to be removed, select it and click on the **Trash Can** (14) to delete it.

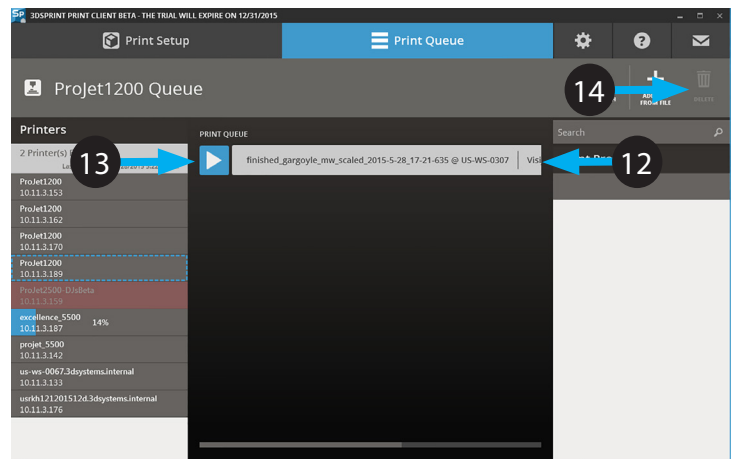

Z Compensation

Z Compensation is a setting in **Printer > Tools > Settings**. Z Compensation allows the user to compensate for overcuring of downfacing surfaces.

Z Compensation works for most geometries, including small internal holes and features greater than 0.1mm thick. Required Z Compensation will be different for each material. If a part is less than 0.1mm thick in some places, it is recommended to use 0 Z Compensation and try orienting the part with critical surfaces or features pointing upwards to reduce the amount of part finishing required.

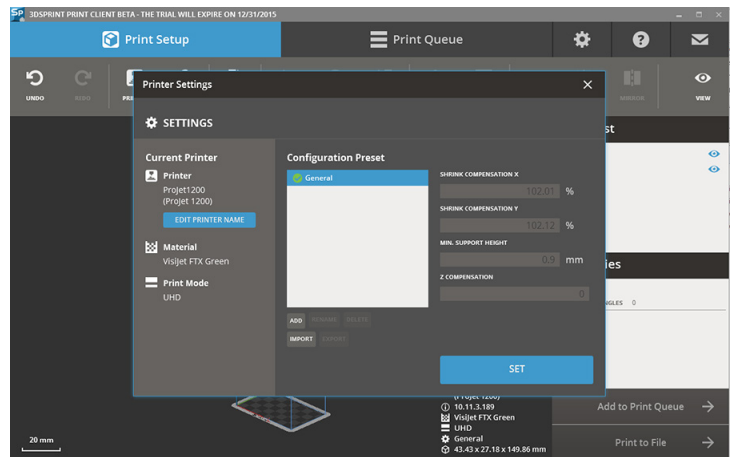

This table will help determine the amount of Z Compensation that may be required when preparing your part for printing.

Distance to Compensate (mm)	Number of Layers to Enter Into Printer Settings	Distance to Compensate (in.)	Number of Layers to Enter Into Printer Settings
0.03	1	0.001	1
0.06	2	0.002	2
0.09	3	0.003	3
0.12	4	0.004	3
0.15	5	0.005	4
0.18	6	0.006	5
0.21	7	0.007	6
0.24	8	0.008	7
0.27	9	0.009	8
0.30	10	0.010	8
0.33	11	0.011	9
0.36	12	0.012	10
-	-	0.013	11
-	-	0.014	12

PRINT QUEUE

Use **Print Queue** to handle ongoing prints and queue of all your printers.

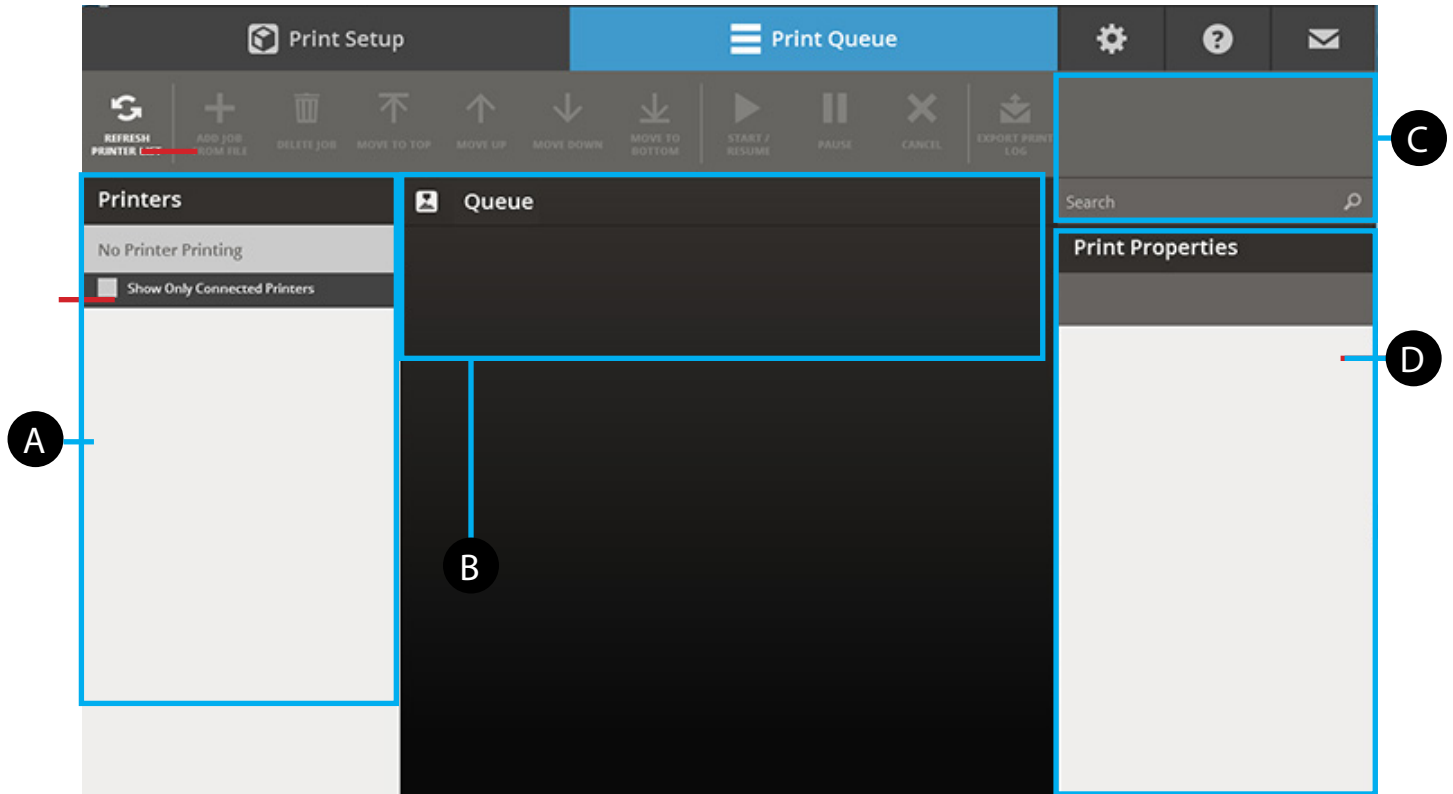

- A Printer List
- B Print Queue
- C Add print, Delete print and search for prints
- D Selected print properties

How to Use:

Print Queue Navigation

To print your job click on the Play Button (1a), to pause an ongoing print, click the **Pause** (1b), to abort the print click **Abort** (1c)

To delete a print, select the print and click the 

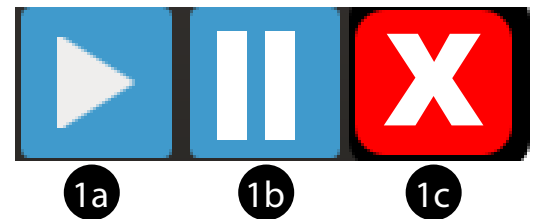

To change the order of the print job, select a pending print job and click up or down arrows (2).

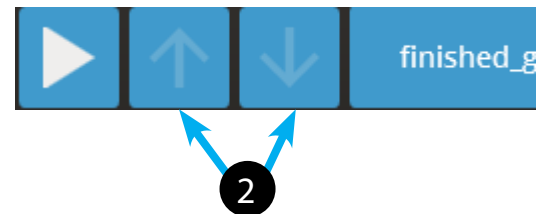

Printer List

See all the connected printers status in the **Printers** panel (selected printer will be highlighted).

- Printer is printing:
- Printer is unavailable:
- Print queue has warnings that need attention:

Print Properties

See the selected print's properties in the **Print Properties** panel:

Adding a File to the Queue

1. Click **Add to Queue** 
2. Navigate to print file and click **Open**.

The print will be added to the queue.

Printers

1 Printers Printing

ProJet1200 192.168.1.1	
ProJet1200 192.168.1.19	
My Printer 192.168.1.10	33%

My Printer 192.168.1.1	33%
----------------------------------	-----

My Printer 192.168.1.1

 My Printer 192.168.1.1
--

Print Properties

Now Printing 33%

Material	
TIME REMAINING	0:10
ESTIMATED COMPLETION	28/10/2014 17:18

REMOVE THE PART FROM THE PRINTER

After the part has been printed, it must be processed. Refer to the following steps to complete post processing of the part. You will need a towel to catch resin that may drip from the part as well as two containers of 70% alcohol large enough to completely submerge the part. It is important to limit the exposure of the material cartridge to light.



Always wear protective gloves during post process.



CAUTION: Always follow the precautions noted on the MSDS sheets for any chemical being used.

1. Place a towel under the part. Rotate the print platform clamp lever up enough to unlock the print platform.



NOTE: Resin may drip from the part. The towel is used to collect dripping resin so that printer parts are not exposed to resin.

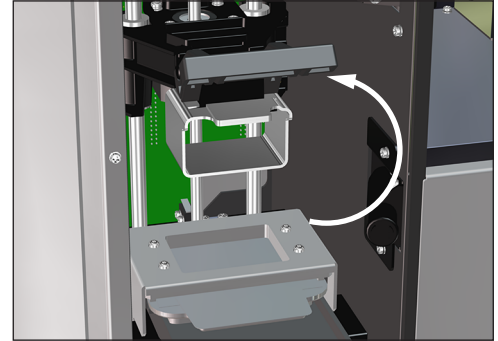

2. Pull the print platform handle (A) out from under the clamp.



NOTE: The part will hang down under the print platform.

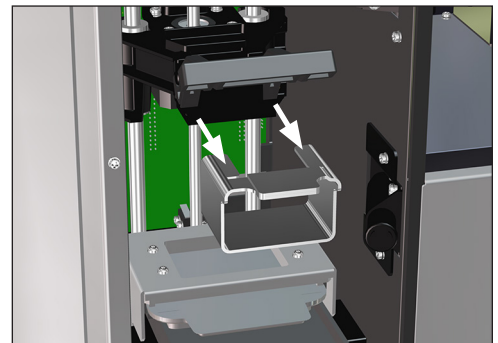
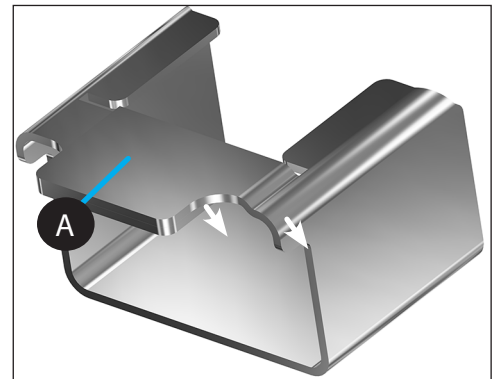

CLEANING PARTS

The following equipment is needed for cleaning parts produced by the ProJet 1200.

Glass containers with lids

- 16 oz,
- 3.5 inch diameter opening (minimum)
- This size will hold parts that are “ring height”.

Digital timer

99% isopropyl alcohol (IPA), optionally you may use 70% IPA

Ultrasonic cleaner (Optional)

- Digital timer
- Volume: 28 liter (0.75 gal)
- Stainless steel Tank: 9 x 5 x 4 inch



WARNING: 99% AND 70% ISOPROPYL ALCOHOL. FLAMMABLE LIQUID AND VAPOR. KEEP AWAY FROM HEAT, SPARK AND OPEN FLAMES. USE WITH ADEQUATE VENTILATION. STORE AT 68-86°F. DO NOT TAKE INTERNALLY. AVOID PROLONGED OR REPEATED BREATHING OF MIST OR VAPOR. CAUSES IRRITATION TO EYES AND RESPIRATORY TRACT. AFFECTS CENTRAL NERVOUS SYSTEM. MAY BE HARMFUL IF ABSORBED THROUGH SKIN. MAY CAUSE IRRITATION TO SKIN.



Wear Gloves: Always wear gloves when cleaning parts.

Cleaning Parts by Manually Dipping

1. Mark glass containers as “Container 1” and “Container 2”
2. Place print platform into Container 1.
3. Add 99% IPA to Container 1. Use enough IPA to completely submerge the parts.
4. Using the print platform handle, continuously dip and remove the part into Container 1 for 60 seconds.
5. Remove parts from Container 1. Allow excess alcohol to drip from the parts for 30 seconds.
6. Place print platform into Container 2.
7. Add 99% IPA to Container 2. Use enough IPA to completely submerge the parts.
8. Using the print platform handle, continuously dip and remove the parts into Container 2 for 90 seconds.
9. Remove parts from Container 2. Allow excess alcohol to drip from the parts for 30 seconds.
10. Use clean compressed air (not over 30 psi), to dry the part.
11. Inspect the part closely to make certain no liquid resin remains. Pay particular attention to shiny areas. The part may appear shiny even if there is no liquid resin remaining. If you are unsure if liquid resin remains, it is best to repeat steps 8 through 10.

Make certain you replace the lids on Containers 1 and 2 when they are not in use.

Containers 1 and 2 can be used to clean 12 platforms before discarding and replacing the IPA.

Cleaning Parts Using an Ultrasonic Cleaner

1. Mark glass containers as "Container 1" and "Container 2"
2. Place print platform into Container 1.
3. Add 99% IPA to Container 1. Use enough IPA to completely submerge the parts.
4. Replace the lid onto Container 1.
5. With the ultrasonic cleaner switched off, place Container 1 into the ultrasonic cleaner.
6. Add water to the ultrasonic cleaner until the water level is approximately 6mm (1/4 inch) above the alcohol level in Container 1.
7. Switch the ultrasonic cleaner on for 60 seconds.
8. Switch ultrasonic cleaner off and remove Container 1 from the ultrasonic cleaner.
9. Remove parts from Container 1. Allow excess alcohol to drip from the parts for 30 seconds.
10. Place print platform into Container 2.
11. Add 99% IPA to Container 2. Use enough IPA to completely submerge the parts.
12. Replace the lid onto Container 2.
13. Place Container 2 into the ultrasonic cleaner. Make certain the water level is approximately 6mm (1/4 inch) above the alcohol level in Container 2.
14. Switch the ultrasonic cleaner on for 90 seconds.
15. Switch ultrasonic cleaner off and remove Container 2 from the ultrasonic cleaner.
16. Remove parts from Container 2. Allow excess alcohol to drip from the parts for 30 seconds.
17. Use clean compressed air (not over 30 psi), to dry the parts.
18. Inspect the part closely to make certain no liquid resin remains. Pay particular attention to shiny areas. The part may appear shiny even if there is no liquid resin remaining. If you are unsure if liquid resin remains, it is best to repeat steps 10 through 17.

Make certain you replace the lids on Containers 1 and 2 when they are not in use.

Containers 1 and 2 can be used to clean 12 platforms before discarding and replacing the IPA.

Special Consideration when Cleaning Parts

When performing the cleaning procedures provided above, you may find that it is more difficult to remove the resin from certain parts or particular areas of a part. The geometry of the part or the orientation of the part on the platform may result in the following:

- The part may hold a large amount of liquid resin in a cavity

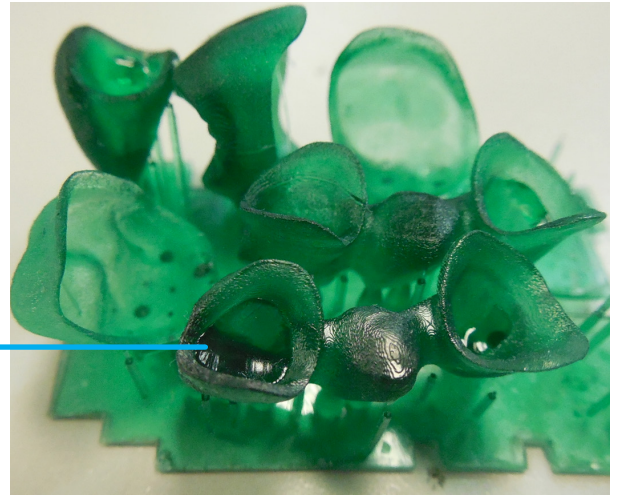

- An air bubble may be trapped preventing the isopropyl alcohol from contacting the part.

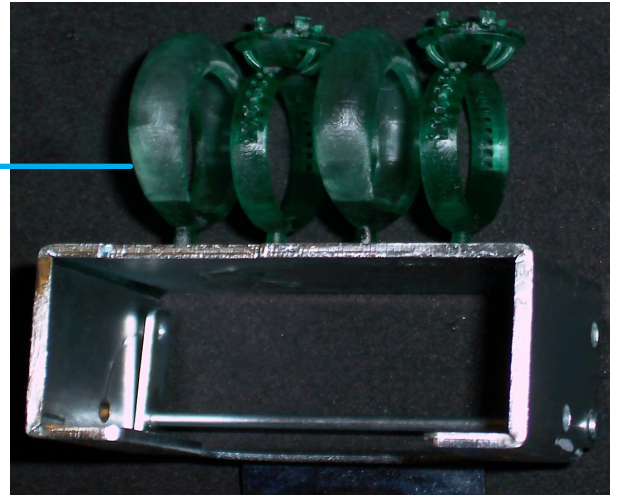

In these cases, change the orientation of the parts when cleaning. Rotate the print platform 90 or 180 degrees to release trapped air bubbles. This will also expose areas of the part which are saturated with liquid resin, allowing better exposure to the isopropyl alcohol.

Changing the Isopropyl Alcohol in Containers 1 and 2

The isopropyl alcohol in Container 1 and Container 2 must be replaced after cleaning 12 platforms. The discarded alcohol is contaminated with uncured resin and is considered hazardous waste. The discarded alcohol must be stored and disposed of in accordance with all local, state and federal regulations.

Cleaning Parts with 70% Isopropyl Alcohol

You may use 70% (as opposed to 99%) isopropyl alcohol to clean parts. Using 70% IPA requires the following minor modifications to the cleaning procedures:

- The cleaning times increase: 2 minutes in Container 1 and 90 seconds in Container 2.
- It will take longer to dry the parts with compressed air.
- The isopropyl alcohol in Container 1 and Container 2 must be replaced after cleaning 6 platforms.

The discarded alcohol is contaminated with uncured resin and is considered hazardous waste. The discarded alcohol must be stored and disposed of in accordance with all local, state and federal regulations.

Cure and Post Process the Part

1. After the part is completely dry, insert the print platform onto the curing chamber carousel.
2. The curing chamber carousel has metal tabs on top that secure the print platform. Slide the print platform under the tabs.
3. Close and latch the curing chamber door.

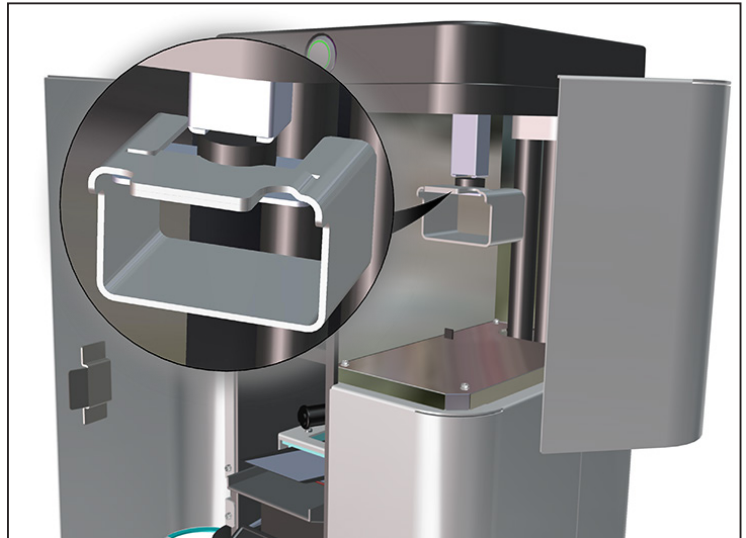

4. Select **Start Post Cure** (1) from the **Printer Tools** (2) button.
5. A dialog box will pop up asking to **Stop** or **Start** the Post Cure process. Select **Start** and click **Close**.
6. Curing the part will take approximately 30 minutes. Do not open the curing chamber door until the curing process has been completed.

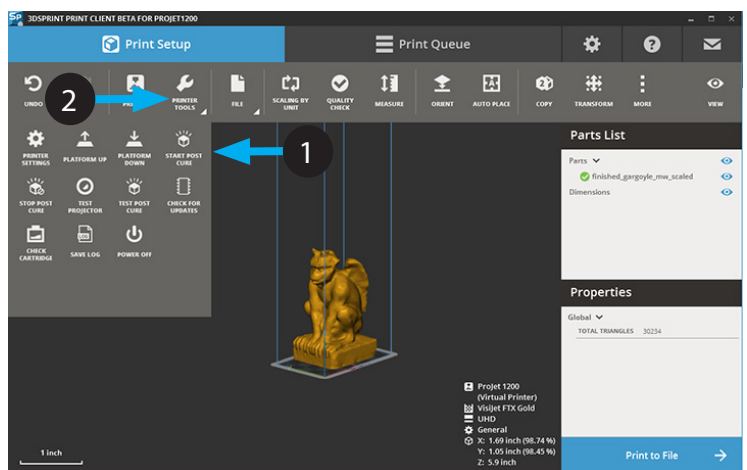

7. Once the part has been cured, remove the print platform from the curing chamber carousel.
8. Using a blade, carefully scrape the part off the print platform.
9. Use your fingers, remove the base from the part.
10. Use fine grit sandpaper to sand down the unwanted protrusions from the bottom of the part.
11. Apply Isopropyl alcohol to a soft cloth and gently clean the part.

8 USER MAINTENANCE

The following procedure are maintenance procedures that can be performed by the user. When performing the following procedures, the user must follow all safety precautions as described in the Safety section of this manual.

REPLACING THE CURING BULB



CAUTION: Do not touch the curing bulb. Keep the protective sleeve on the bulb until after the bulb has been installed.



CAUTION: Exercise caution when installing the bulb. If the printer is rotated to its side or upside down, the glass plane under the material cartridge support assembly may dislodge or become damaged. It is strongly recommended that the packing foam is inserted into the material cartridge support and then the cartridge clamp secured with the material cartridge clamp lever.

1. Remove print platforms from the build chamber and curing chamber. Remove material cartridge from the printer.
2. Place the plastic insert (A) on the material cartridge support and lower the clamp lever (B) to secure it.

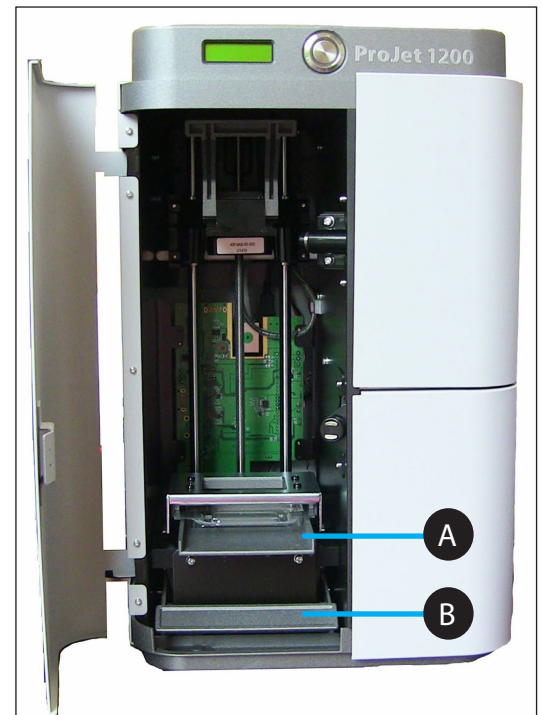

1. Holding on to the bulb with tissue or paper towel, gently pull bulb down out of socket (1).
2. After bulb is loose from socket, lift it out of the machine (2).
3. To replace the bulb, follow the procedure, **Installing the Curing Bulb** on page 14.

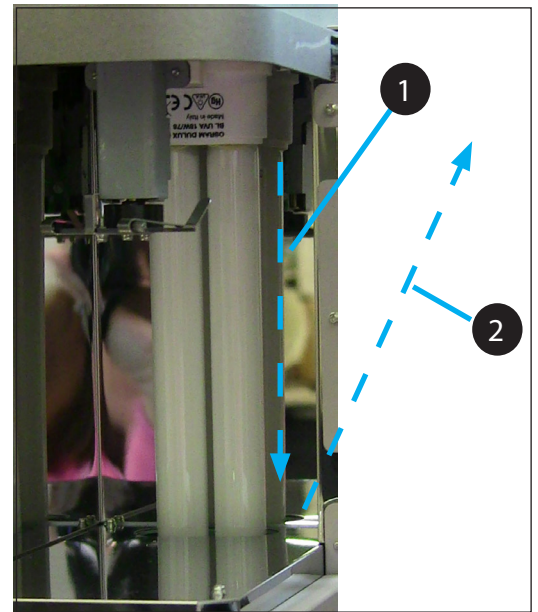

CLEANING THE UNIT

The internal parts of the build and curing chamber can be wiped clean with 70% isopropyl alcohol and a soft, non-scratching cloth, (such as a microfiber). Make certain you inspect the glass that is a part of the print cartridge support. Remove the glass and clean any resin, fingerprints or any other debris which may have accumulated.

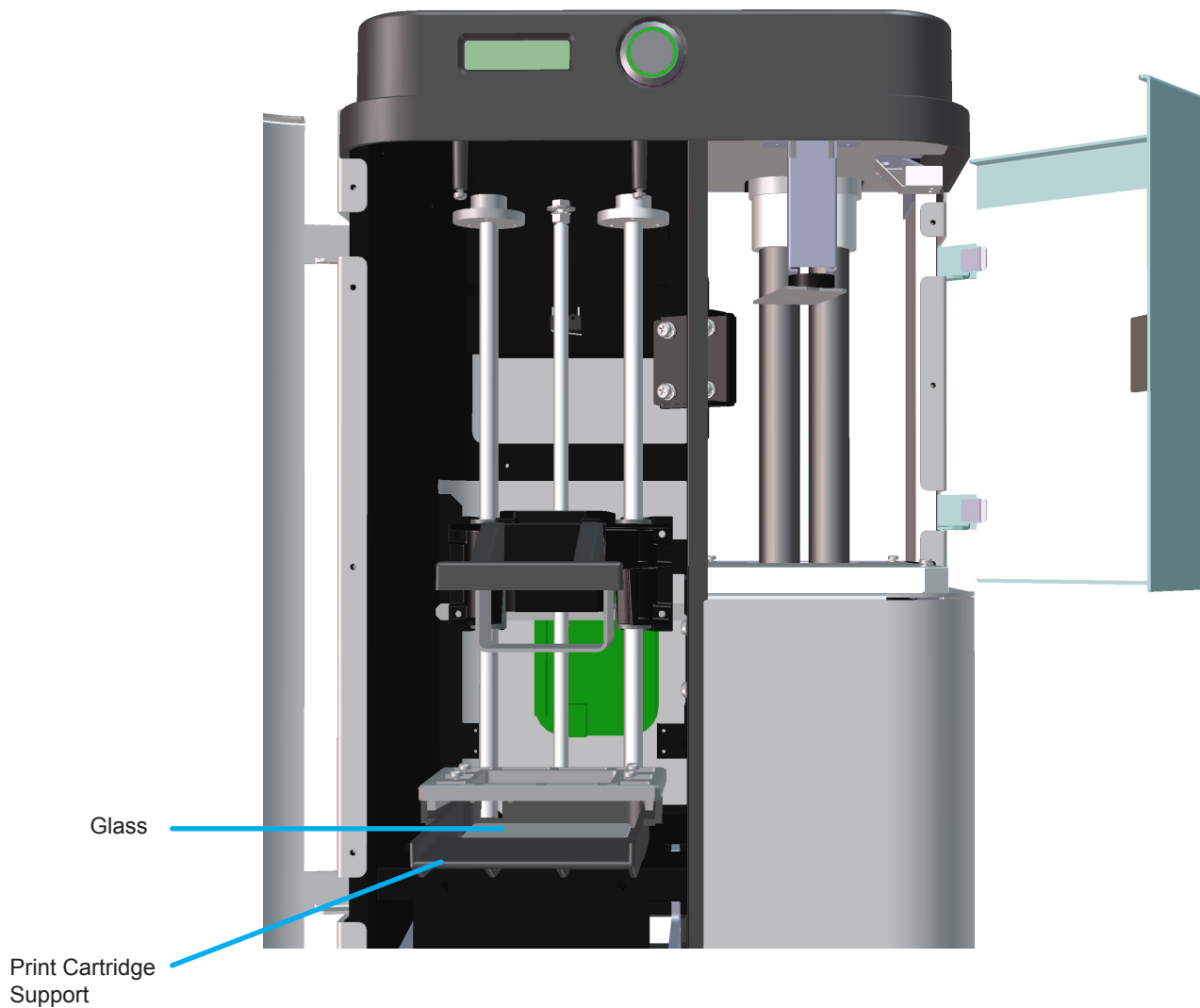

9 SERVICE AND SUPPORT

Should additional questions arise, contact 3D Systems:

SERVICE CONTACT

Hotline	Every workday: 8:00 - 17:00 EST/EDT 1.800.793.3669
E-Mail	moreinfo@3dsystems.com
Service Address U.S.A	3D Systems Inc. 333 Three D Systems Circle Rock Hill, SC 29730
Service Address Japan	3D Systems, Japan K.K. 4-6-8 Tsurumaki Setagaya-Ku, Tokyo 154-0016
Service Address Europe	3D Systems Europe Ltd. Mark House, Mark Road Hemel Hempstead Herts HP2 7UA United Kingdom

REPACKING THE PROJET 1200

At some point the ProJet 1200 may need to be moved or sent back for servicing. It is important to keep all the original packaging to facilitate this process. Follow these steps to safely repack your ProJet 1200.

1. Disconnect all cords from the ProJet 1200.
2. Remove material cartridge as described on Page 15
3. If dummy cartridge was displaced during shipping, raise the cartridge lock lever to the up position (if not already up), slide the dummy cartridge in and place the cartridge lock lever to the down position.

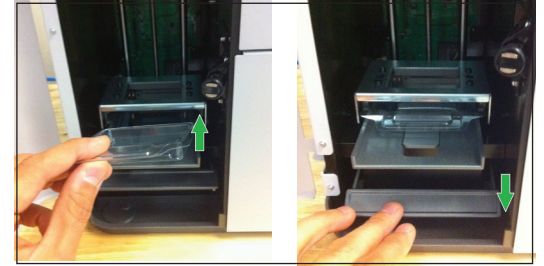

4. Apply a ~6 inch piece of painter's tape (or any tape that does not leave a residue) starting from the cartridge lock lever to the bottom of the machine. Ensure the lever does not have any slack.



NOTE: Always wear nitrile gloves when installing or removing the material cartridge to ensure no material spills onto skin.

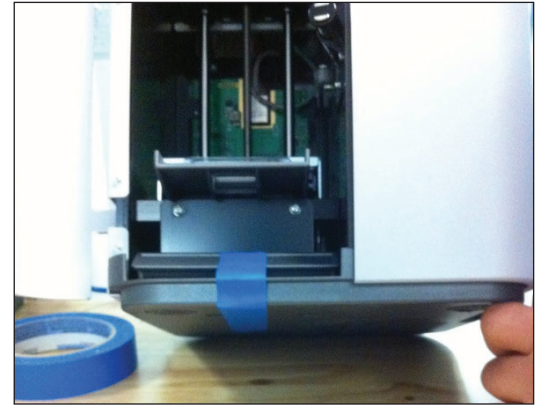

5. Pack them back into the cardboard box that they came in.
6. Carefully place the printer in the lower boxed foam support.



7. Place the upper foam insert (A) on the top of the printer. Place the peripherals box (B) on top of the foam insert as shown.

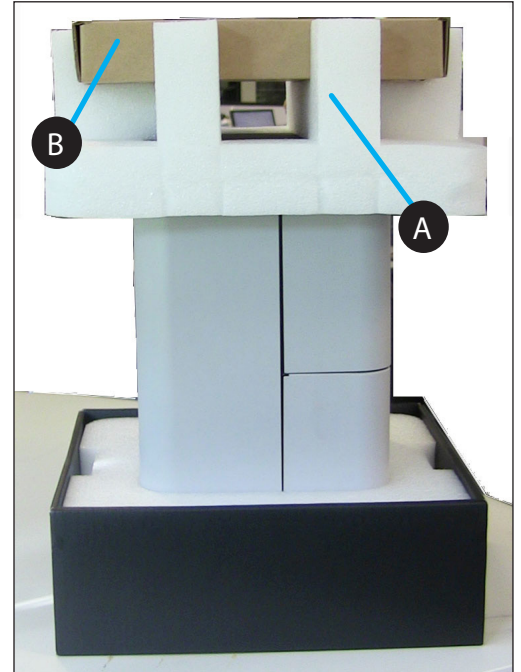

8. Place original box over top of printer so it covers entire machine.
9. Insert plastic handles in holes on the sides of the box.

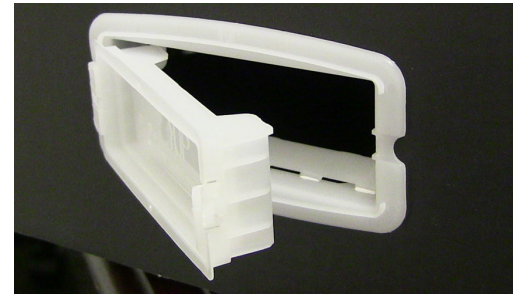

10. Press tabs (A) into side of plastic insert to secure handles to the box.





3D Systems, Inc.
333 Three D Systems Circle | Rock Hill, SC | 29730
www.3dsystems.com

©2014 3D Systems, Inc. All rights reserved.